



STELLAR® CABLE HOIST TECHNICAL SPECIFICATION GUIDE

SI60 / SI75

60,000 - 75,000 Capacity Cable Hoist



Our People. Our Products.

STELLAR® CABLE HOIST TECHNICAL SPECIFICATION GUIDE

■ STANDARD EQUIPMENT

Hoist rated capacity	60,000 lbs.
Main frame	8" x 4" x 1/2" A500 C tubing
Sub frame	4" x 2" x 1/4" A500 C tubing
Front stop	1-1/2" plate
Container lock	Automatic spring loaded
Lift cylinder shaft	2-1/2" plate
Rear hinge shaft	3" solid steel
Cable	7/8" (6 x 37 EXIWRC)
Cable sheaves	10" O.D. bronze-bushed sheave
Cable anchor	4 cable clamps
Cable end	Steel casting
Rear hold down	1" plate located for std. containers
Middle hold down	3/4" plate
Lift cylinders	6" x 72" D.A.
Reeving cylinders	7" x 80" D.A.
Direct mount pump	Gear types 35 GPM @ 1500 RPM
Operating pressure	1850 PSI
Hydraulic valve	2 spool 45 GPM safety bypass
Hydraulic reservoir	60 gal. 25 micron filter & screen filter
Outside rollers	4" O.D. with bronze bearing
Inside rollers	6" O.D. hardened roller & pins
Working points	Greaseable
Safety stand	Factory installed
I.C.C. Bumper	Folding, mounting lugs factory installed
Rear bumper	Pre-drilled bolt mount - sealed beam backup, clearance and tail lights
Hoist up	30 sec. approx.
Hoist down	15 sec. approx.
Cable in	46 sec. approx
Cable out	37 sec. approx.
Container length	18' - 22'
Approximate weight	6100 lbs.
Mud flaps	Flex rubber, bolt-on
Tail frame	3" x 7" A500 C tubing with (2) 1/2"
Hydraulic valve	3 spool 45 GPM safety bypass
Cable end	Steel casting, knuckle-type
Rear flange roller	8" O.D. hardened w/2 1/2" c-1045
Rear center sheave	8" O.D. hardened

■ OPTIONAL EQUIPMENT

Hoist rated capacity	75,000 lbs.
75,000 lb. Capacity cable	1" (6 x 37 EXIWRC)
Lift Cylinder- T Models	6" x 72" (5.5 x 4.5" x 3.5" x 125") Telescopic Cylinders
Inside controls	Direct connect, cable or pneumatic
Remote mount hydraulic pump	Gear type 35 GPM @ 1500 RPM
Auxiliary fold down front stops	For short containers
Full fenders	Tandem or tri-axle, 12 ga. steel or poly
Tarp rack / tool box combination	20" x 16" x 48"

4 Spool valve
 "Drop-in" Stops
 Cab Guard
 Drop-center cylinder mounting shaft
 PTO air operated with signal light
 Hoist-up alarm

Single - acting hydraulic line to rear*
 Double - acting hydraulic line to rear*
 Double - acting hydraulic line to side*

*Note: This requires the 3 spool valve option or selector valve

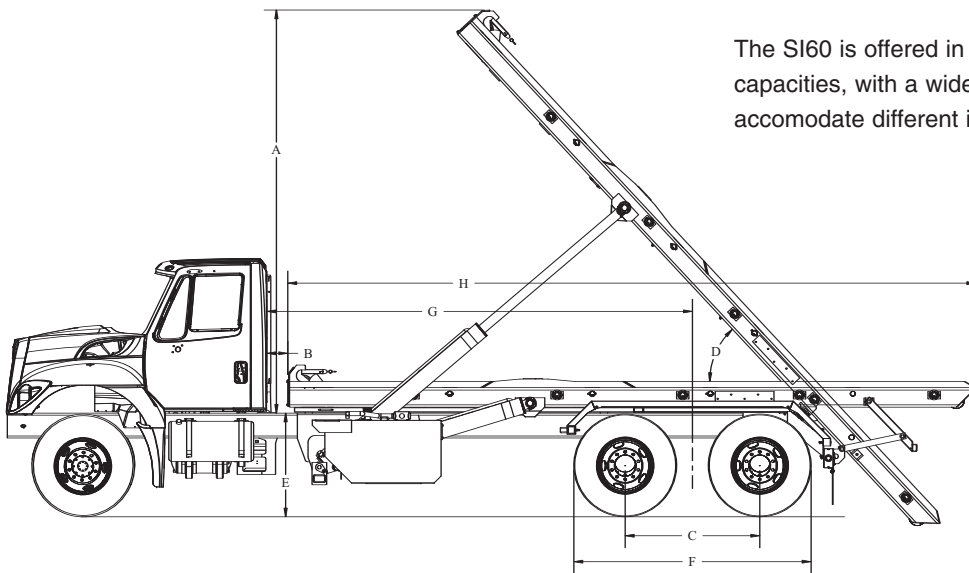

The SI60 is offered in 60,000 and 75,000 lb. capacities, with a wide selection of models to accommodate different industry requirements.

■ **OUTSIDE RAIL SERIES**

Model	A	B	C	D	E	F	G	H
SI60-174OR	166"	5-6"	51-55"	47°	43" Max	96" Max	174"	281"
SI60-182OR	172"	5-6"	51-55"	47°	43" Max	96" Max	182"	289"
SI60-194OR	178"	5-6"	51-55"	47°	43" Max	96" Max	194"	301"

■ **OUTSIDE RAIL SERIES W/ EXTENDABLE TAIL (TAIL EXTENSION ADDS 80" AT FULL EXTENSION)**

Model	A	B	C	D	E	F	G	H
SI60-174ORX	166"	5-6"	51-55"	47°	48" Max	96" Max	174"	237"
SI60-182ORX	174"	5-6"	51-55"	47°	48" Max	96" Max	182"	245"
SI60-194ORX	178"	5-6"	51-55"	48°	48" Max	ORT Specs	194"	257"

■ **INSIDE/OUTSIDE RAIL SERIES**

Model	A	B	C	D	E	F	G	H
SI60-174IO	166"	5-6"	51-55"	47°	43" Max	96" Max	174"	281"
SI60-182IO	172"	5-6"	51-55"	47°	43" Max	96" Max	182"	289"
SI60-194IO	178"	5-6"	51-55"	47°	43" Max	96" Max	194"	301"

■ **INSIDE/OUTSIDE RAIL SERIES W/ EXTENDABLE TAIL (TAIL EXTENSION ADDS 40" AT FULL EXTENSION)**

Model	A	B	C	D	E	F	G	H
SI60-174IOX	166"	5-6"	51-55"	47°	48" Max	96" Max	174"	279"
SI60-182IOX	172"	5-6"	51-55"	47°	48" Max	96" Max	182"	287"
SI60-194IOX	173"	5-6"	51-55"	48°	48" Max	IOT Specs	194"	298"

Legend
OR Outside Rail
ORX Outside Rail Extendable Tail
IO Inside/Outside Rail
IOX Inside/Outside Rail Extendable Tail
ORT Outside Rail Telescopic
IOT Inside/Outside Rail Telescopic

Your local dealer:



Our People. Our Products.

190 State Street
P.O. Box 169
Garner, IA 50438
Telephone: (641) 923-3741 • (800) 321-3741
Fax: (641) 923-2812
Internet: www.stellarindustries.com
Email: sales@stellarindustries.com