



STELLAR SHUTTLE
MODEL 190-24-65 G
ASSEMBLY
AND
INSTALLATION
MANUAL



Table of Contents

Hydraulic Hook Lift Specifications.....	2
Base Assembly	3
Dump Assembly	4
Secondary Assembly.....	5
Tilt Assembly	6
Installation Instructions.....	7
Mounting Kit	8
Safety Valve Installation.....	9
Rotary Valve Assembly	10
35 Gallon Tank Assembly.....	11
Hydraulic Assembly	12
Controller Assembly	13
Mounting Kit, 35 Gallon Tank	14
Bumper Mounting.....	15
Miscellaneous Parts	15
Subframe	16
Warranty.....	17

Hydraulic Hook Lift Specifications

Lifting Capacity:	65,000 pounds gross weight evenly distributed in, or on, body.
Container Length:	19-foot through 24-foot from front A-frame to rear of skid rails. Longer bodies may be accommodated if full dump angle is not required (may require special body-mounted or extendable truck-mounted bumper to meet the Office of Motor Carrier Safety (OMCS) Rear End Protection regulation 393.86)
Maximum Dump Angle:	45°
Operating Pressure:	4200 PSI maximum
Weight of Loader:	Loader weight not to exceed 7,400 pounds
Height of Loader:	Loader height not to exceed 11.56' as measured from top of truck frame to top of loader rollers
Hook Height:	61.75-inches from bottom of skid rails to centerline of hook bar. Loader must be able to pick up 10-inches below grade when mounted on a truck with 41" frame height.
Hydraulic Pump:	Direct-coupled high-pressure gear pump.
Hydraulic Control Valve:	Stack-type valve mounted directed onto the oil reservoir.
Controls:	Dual manual levers with sealed cable actuators mounted in the truck cab to allow full feathering of all loader functions.
Tilting Hook Assembly:	Loader must have pivoting type front tilt section (jib) to provide a low degree loading/unloading angle. Hook to include automatic mechanical safety latch, which disengages only when the container/body is in proper position to be picked up or dropped off.
Tilt Cylinder:	Single 5-inch bore with 2.5-inch diameter rod cylinder. Cylinder must be double acting and include dual integral pilot-operated counterbalance valves to prevent cylinder collapse in case of hose failure.
Tilt Section Operation:	Loader must include a hydraulic lock-out device to prevent operation of the tilt section while loader is in the dumping mode.
Lift/Dump Cylinder:	Dual 7-inch bore with 3.0-inch diameter rod cylinder. Cylinder must be double acting and include dual integral pilot-operated counterbalance valves to prevent cylinder collapse in case of hose failure.
Dump/Tilt Interlock:	Dumping must be accomplished through a rear pivot. Tilt and lift sections must lock into a rigid full length 34" wide frame with front saddles to provide support for the container while in the dump mode. These sections form this frame without the use of mechanical latches, which rely on gravity, springs, or container/body mounted latches.
Rear Body Hold-Downs:	Dual fixed-position hold-down devices mounted to the dump frame to secure the body to the loader through all ranges of the dump mode. This must be accomplished without the use of steel springs and/or hydraulic/air cylinders.
Rear Dump Hinge Pin:	3-inch diameter hardened, chrome-plated steel minimum
Pins & Bushings	All pins to be hardened chrome steel. All bushings to be of the permanently lubricated variety. No grease zerks allowed.
Hoses & Hydraulic Fittings:	All hoses and fittings are to be SAE: metrics not allowed. O-ring face seal fittings to be utilized wherever possible.
Origin of Manufacture:	Loader to be designed and manufactured in the United States of America.

Base Assembly

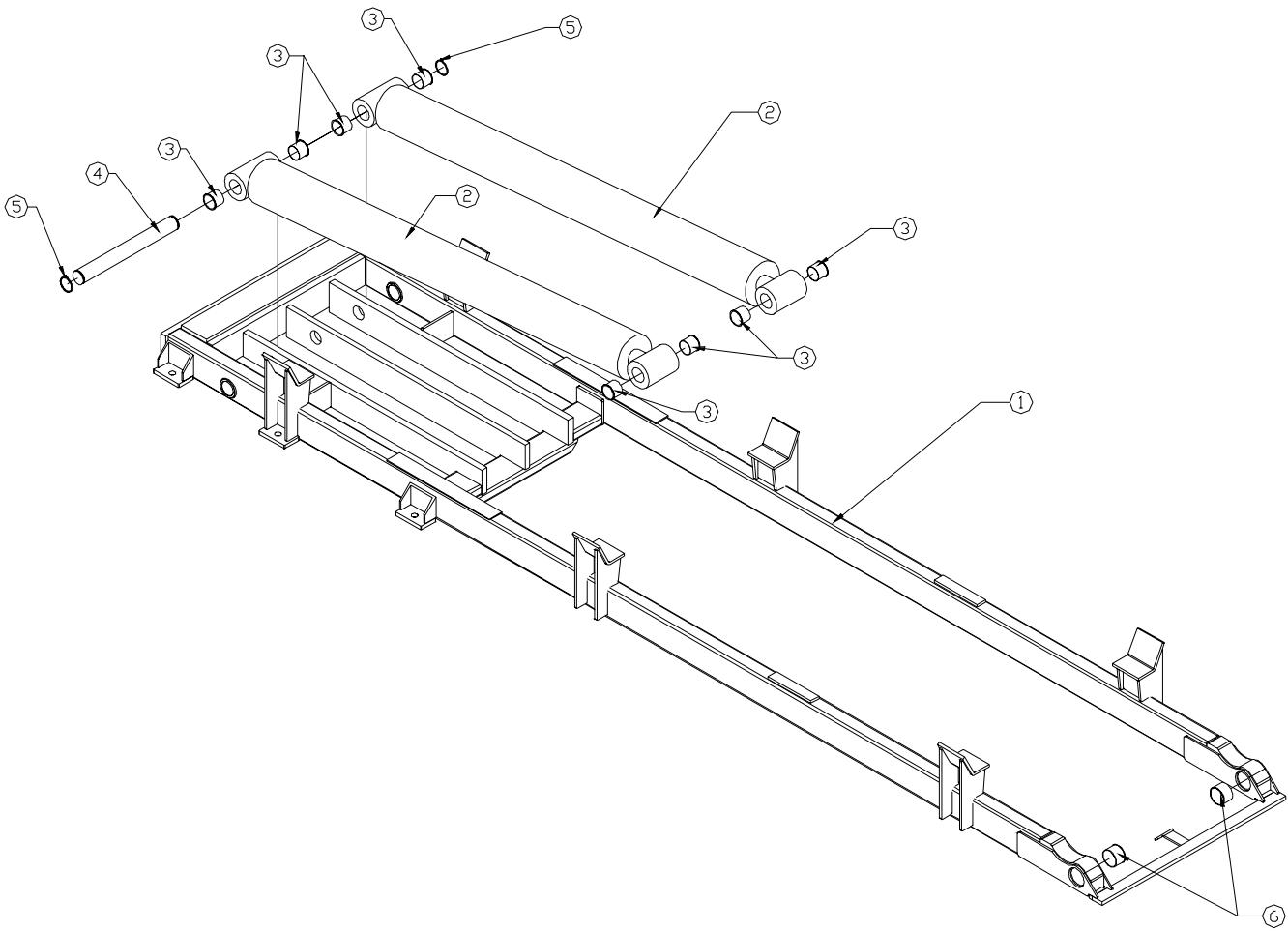

ITEM	P/N	DESCRIPTION	QTY
1	D0151	Base Weldment	1
2	0811	Cylinder, 7.00x71.63	2
3	0635	Bushing, 40DXR32	8
4	2886	Pin, 2.50x22.50	1
5	0636	Snap Ring, 2.50	2
6	0865	Bushing, 48DXR32	2

Dump Assembly

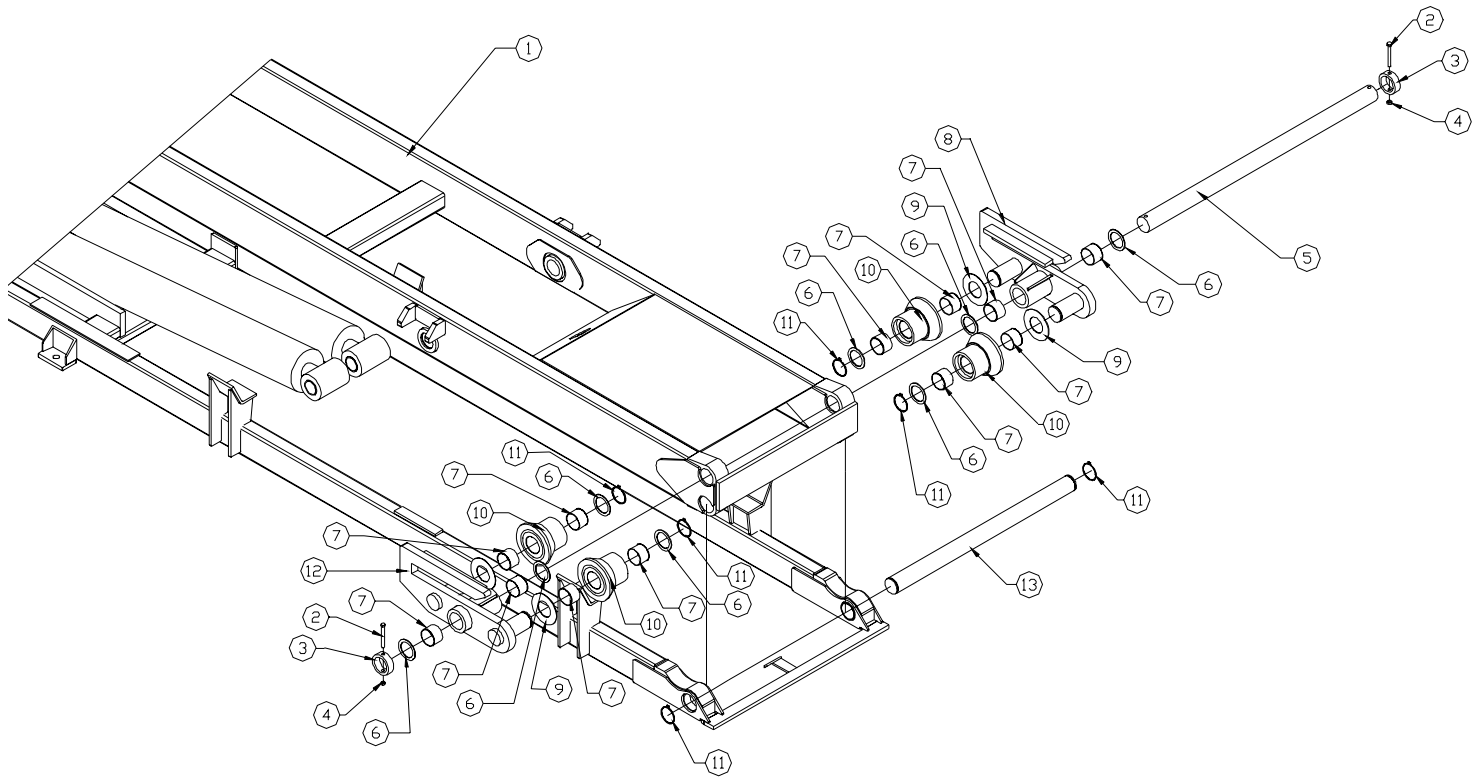

ITEM	P/N	DESCRIPTION	QTY	ITEM	P/N	DESCRIPTION	QTY
1	3310	Dump Weldment	1	8	3939	Double Roller CS	1
2	0507	Cap Screw, .50-13x4.50	2	9	3798	Washer, 3.06x6.00 UHMW	4
3	2727	Collar, Locking	2	10	2715	Roller	4
4	0360	Nut, .50-13 Nyloc	2	11	2096	Snap Ring, 3.00	6
5	2719	Pin, 3.00x56.00	1	12	3940	Double Roller SS	1
6	1548	Thrust Washer, 3.01 Dia	8	13	2718	Pin, 3.00X44.00	1
7	0865	Bushing, 48DXR32	12				

Secondary Assembly

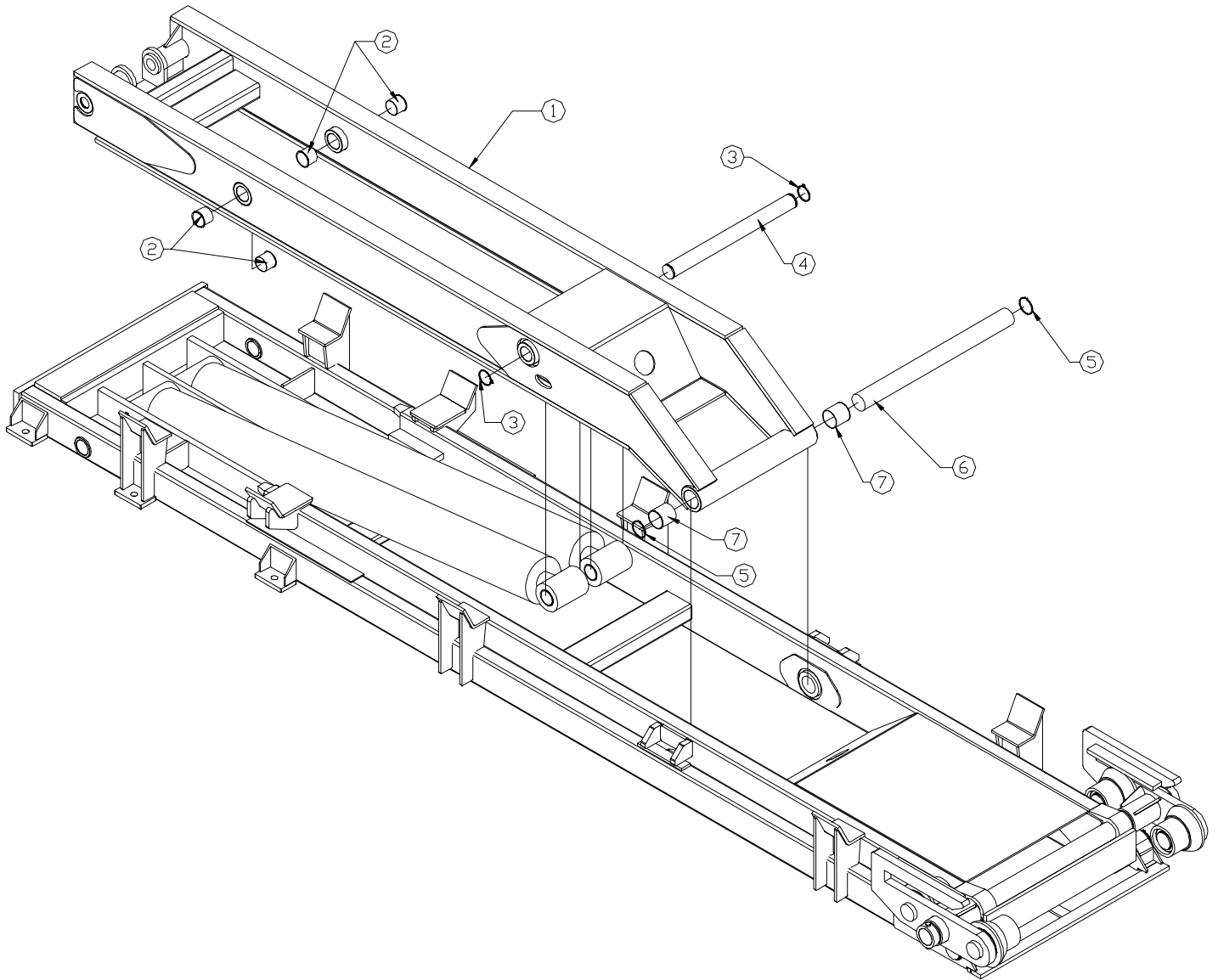

ITEM	P/N	DESCRIPTION	QTY
1	2624	Secondary Weldment	1
2	0635	Bushing, 040DXR032	4
3	0636	Snap Ring, 2.50	2
4	2721	Pin, 2.50x28.25	1
5	2200	Snap Ring, 3.00 Internal	2
6	2720	Pin, 3.00x34.00	1
7	2227	Bushing, 048DXR032	2

Tilt Assembly

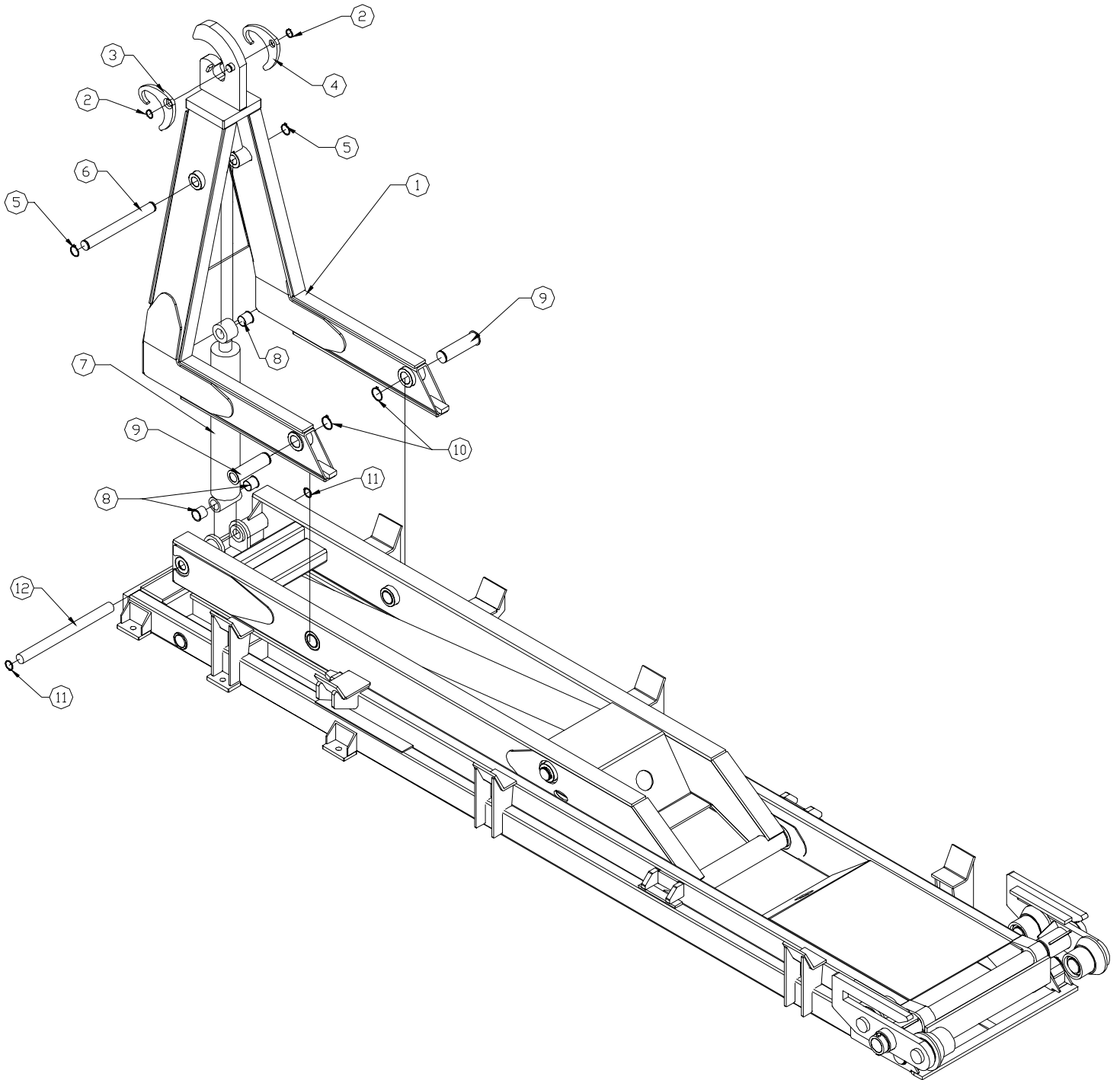

ITEM	P/N	DESCRIPTION	QTY	ITEM	P/N	DESCRIPTION	QTY
1	2625	Tilt Weldment	1	7	3488	Cylinder, 5.00x22.50	1
2	0246	Snap Ring, 1.50	2	8	0066	Bushing, GSI-3235-32	3
3	2899	Latch, SS 52,000#	1	9	2884	Pin Weldment, 2.50x9.00	2
4	2898	Latch, CS 52,000#	1	10	0636	Snap Ring, 2.50	2
5	0108	Snap Ring, 2.00	2	11	2257	Snap Ring, 2.00 Internal	2
6	2723	Pin, 2.00x18.75	1	12	2722	Pin, 2.00x25.00	1

INSTALLATION INSTRUCTIONS

READ ALL INSTRUCTIONS BEFORE PROCEEDING

MOUNT PTO AND PUMP

MOUNT RESERVOIR VALVE COMBO TO TRUCK FRAME

CONNECT SUCTION AND PRESSURE TO TANK, VALVE BANK, AND PUMP

FILL OIL RESERVOIR TO 3" OF THE TOP (DEXTRON II IS RECOMMENDED)

INSTALL CONTROLLERS AND CABLES IN CAB

SET SHUTTLE ON THE TRUCK SO THAT ITS FRONT PLATE IS AT LEAST 3" BEHIND THE CAB. THE SHUTTLE SHOULD BE SET A MINIMUM OF ½" ABOVE THE TRUCK FRAME

SQUARE THE SHUTTLE ON THE TRUCK FRAME

SHORTEN THE TRUCK FRAME TO ABOUT 2" FROM THE REAR TO THE LOADER

USING 1" BOLTS (3 ½" LONG), WASHERS AND NUTS, ATTACH THE 6 MOUNTING CHANNELS TO THE 6 MOUNTS ON THE LOADER

USING THE MOUNTING CHANNELS AS A GUIDE DRILL (12) 1-1/16" HOLES THROUGH THE TRUCK FRAME

LOCATE (2) 6X4X1/2 ANGLES, ITEM 5 ON PAGE 8, AND DRILL (3) 1-1/16" HOLES PER ANGLE THROUGH THE ANGLE AND THE TRUCK FRAME. INSTALL 1" BOLTS (3" LONG), WASHERS AND NUTS AND SECURE PLATES TO THE TRUCK FRAME. THEN WELD THE PLATES DIRECTLY TO THE BASE SECTION OF THE LOADER. THE ANGLES SHOULD HOLD THE BASE A MINIMUM OF ½" ABOVE THE TRUCK FRAME.

LOCATE (2) 6X4X1/2 ANGLES AND FLATS, ITEMS 1 & 2 ON PAGE 8, AND DRILL (3) 1-1/16" HOLES PER ANGLE THROUGH THE ANGLE, PLATE, AND THE TRUCK FRAME. INSTALL 1" BOLTS (3" LONG), WASHERS AND NUTS AND SECURE PLATES TO THE TRUCK FRAME. THEN WELD THE PLATES DIRECTLY TO THE BASE SECTION OF THE LOADER. THE ANGLES SHOULD HOLD THE BASE A MINIMUM OF ½" ABOVE THE TRUCK FRAME.

USING 1" BOLTS (3" LONG), WASHERS, AND NUTS SECURE ALL TIE DOWNS TO THE TRUCK FRAME AND THE LOADER

CONNECT HOSES TO VALVE BANK AS INDICATED IN HYDRAULIC ASSEMBLY

SET THE RELIEF VALVE TO 4200 PSI

OPERATE THE LOADER TO ELIMINATE AIR FROM THE SYSTEM

CHECK THE OIL LEVEL AND ADD OIL IF REQUIRED

Mounting Kit

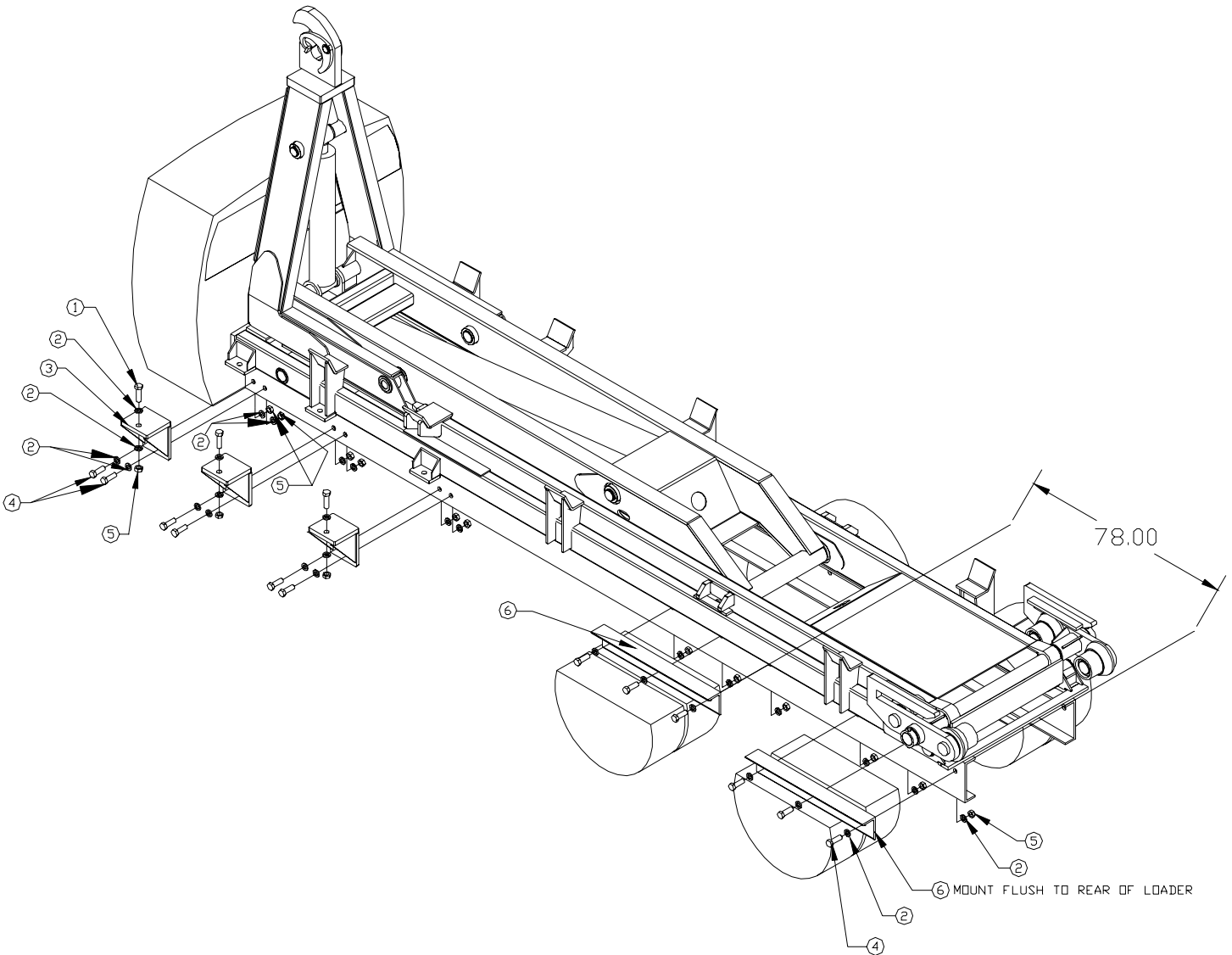

ITEM	P/N	DESCRIPTION	QTY	ITEM	P/N	DESCRIPTION	QTY
1	2830	Cap Screw, 1.00-8x3.50	6	4	1442	Cap Screw, 1.00-8x3.00	24
2	1443	Washer, 1.00 Flat	60	5	2829	Nut, 1.00-8 Nyloc	30
3	2891	Tie Down, 65,000#	6	6	3238	Angle, 4.00x6.00x0.50x36.00	4

Safety Valve Installation

Incorporated into the standard Stellar Hooklift is a safety valve designed to protect the dump section tabs from being damaged by the tilt section.

It is important to locate this valve properly for safe operation of the Stellar Hooklift.

This cartridge is located in the main valve stack and **MUST** be placed off of the tilt cylinder retract port. The following illustrations show a standard (driver side) installation and an optional (passenger side) installation. Passenger side installations are common when mounting to cab-over chassis. All valve stacks are shipped for standard (driver side) installations. The safety valve must be moved to the tilt cylinder retract port for all non-standard installations. This valve will be switched with a load check plug when being moved to an alternate position. A poppet and spring are located behind the safety valve and load check plugs. Care should be taken not to lose these parts when modifying.

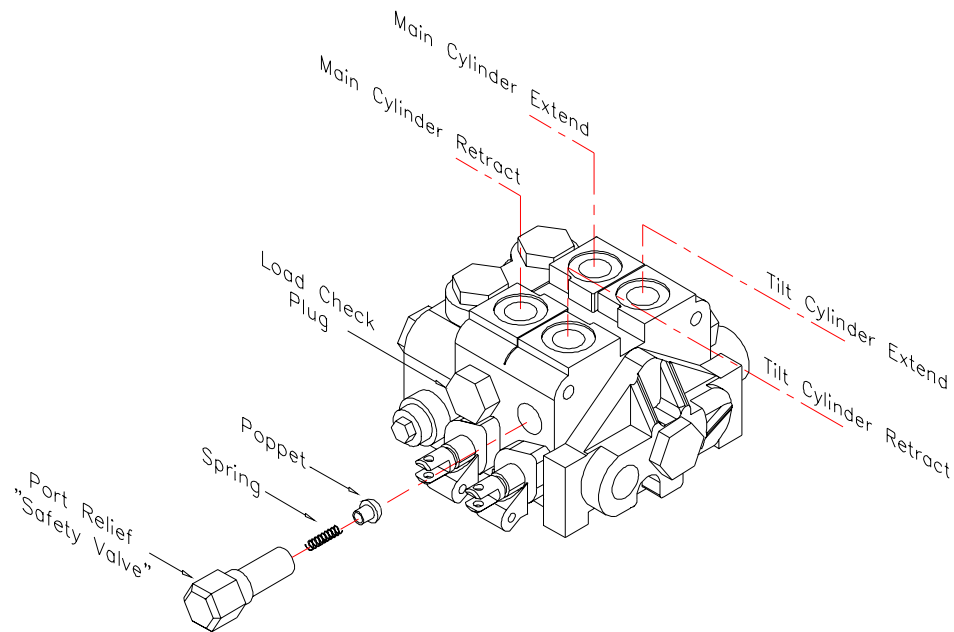

Valve stack for standard installation

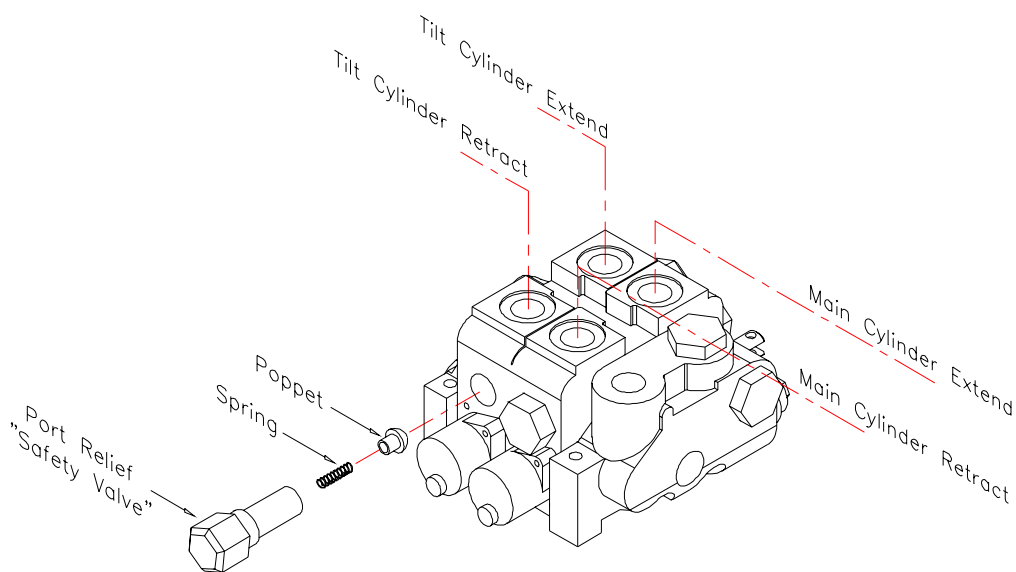

Valve stack for non-standard installation

Rotary Valve Installation

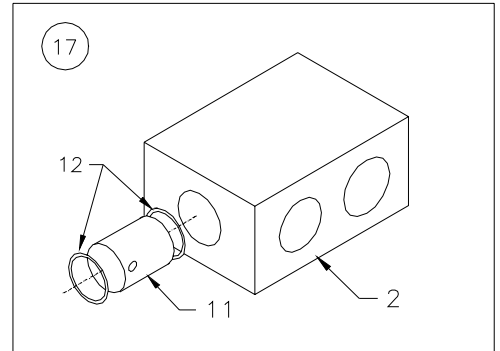
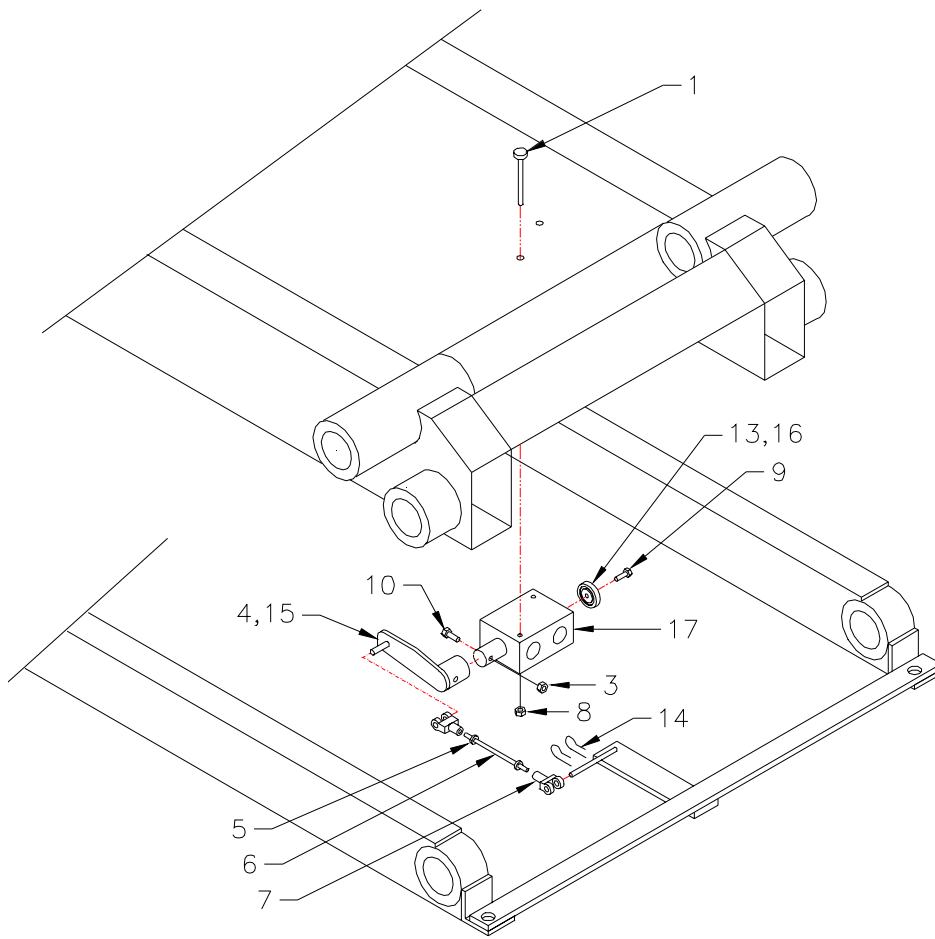

ITEM	P/N	DESCRIPTION	QTY	ITEM	P/N	DESCRIPTION	QTY
1	0482	Cap Screw, 0.25-20x3.00	2	10	0353	Cap Screw, 0.38-16x2.00	1
*2	0933	Body, Rotary Valve	1	*11	D0270	Spool, Rotary Valve	1
3	0347	Nut, 0.38-16 Nyloc	1	*12	0979	Seal, U-Cup	2
4	1521	Rod, Rotary Valve	1	13	3748	Washer, Rotary Valve	1
5	2478	Nut, 0.31-24	2	14	C6113	Cotter, 0.094x1.00	2
6	2476	Rod, 0.31-24 Threaded GR7	12"	15	0977	O'Ring, 1.00x1.25x0.12	1
7	2479	Clevis, 0.31 Pin	2	16	D1638	O'Ring, 1.12x1.38x0.12	1
8	0333	Nut, 0.25-20 Nyloc	2	17	0877	Rotary Valve Assembly	1
9	0480	Cap Screw, 0.25-20x1.00	1				

* Items are part of #17(0877- Rotary Valve Assembly)

35 Gallon Tank Assembly

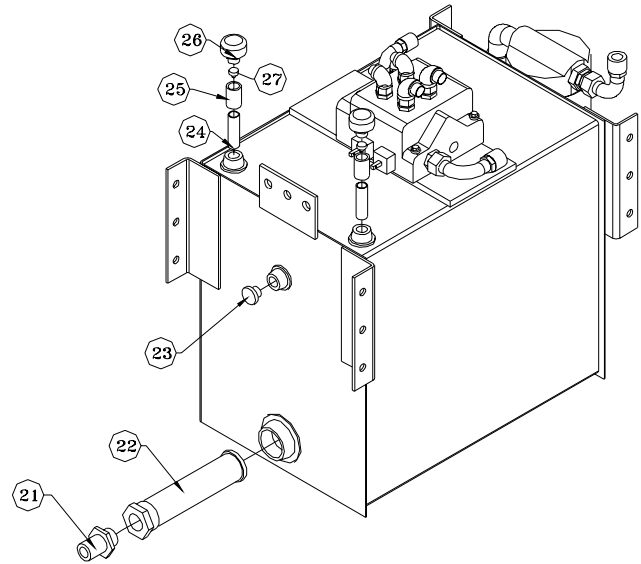
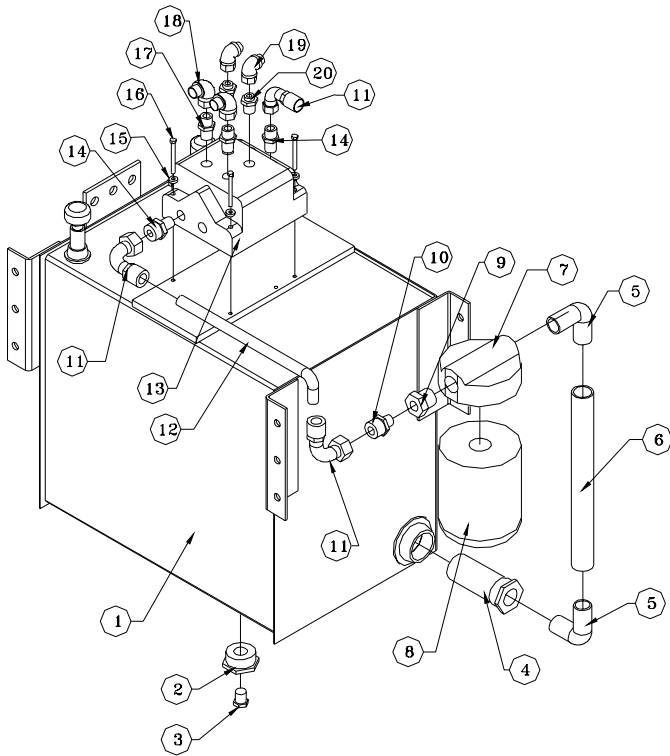

ITEM	P/N	DESCRIPTION	QTY	ITEM	P/N	DESCRIPTION	QTY
1	3500	Tank 35 Gal	1	15	0521	Washer, .25 Lock	3
2	C4825	Fitg, Bush Blk 2.50x.75	1	16	0339	Cap Screw., .25-20x2.50	3
3	C2126	Plug, Magnet .75	1	17	C2252	Fitg, Adapter 8-10 F5OLO-S	2
4	C6328	Diffuser, 25-35 Gal	1	18	C2376	Fitg, Adapter 8-C6LO-S	2
5	C4694	St. Elbow 1.25x90° Blk	2	19	C2248	Fitg, Adapter 6-C6LO-S	2
6	D0024	Nipple, 1.25x14.00 Blk	1	20	C1855	Fitg, Adapter 6-10 F5OLO-S	2
7	C6228	Filter Head SF120-25 1.3	1	21	C4730	Nipple, Barb 2.00	1
8	C6225	Filter Large, SE-10	1	22	C6327	Filter, Strainer TF-2030-0	1
9	C2375	Fitg, Reducer 0102-20-12	1	23	C4955	Sight Gauge, .75 Npt Eye	1
10	C4952	Fitg, Adapter 12 FLO-S	1	24	C1053	Nipple, .75x2.50 Blk Pipe	2
11	C4866	Fitg, Seal Lok 90 1J943-12-12	3	25	C5930	Coupler, .75 Blk	2
12	C1585	Hose, Hyd .75 381-12	24"	26	C2151	Cap, Filler Breather	2
13	C4944	Valve Bank, V-20	1	27	C4282	Muffler, Load Genie	2
14	C2142	Fitg, Adapter 12-F5OLO-S	2				

Hydraulic Assembly

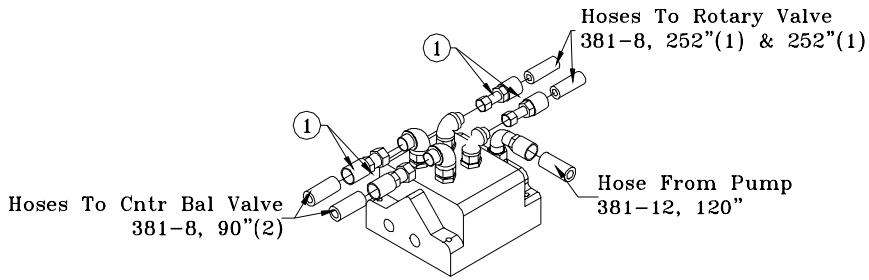

Valve Bank

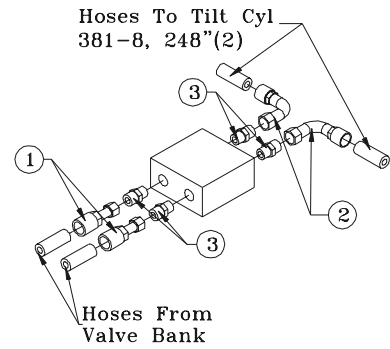

Rotary Valve

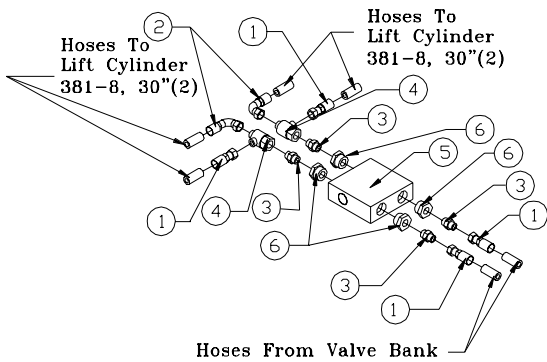

Counter Balance Valve

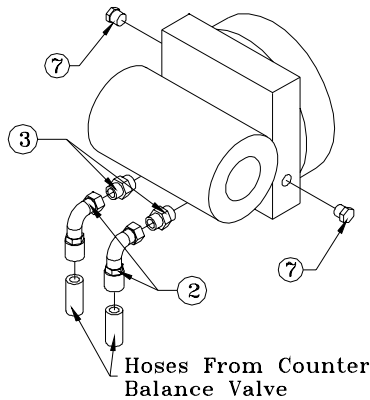

Lift Cylinder (2)

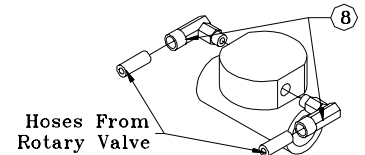

Tilt Cylinder

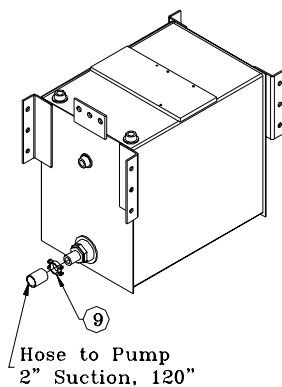

Suction Line

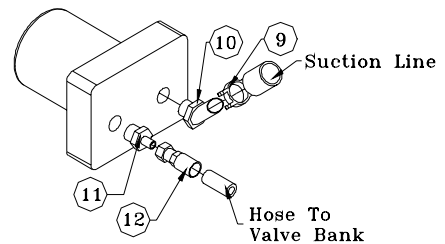

Standard Pump

ITEM	P/N	DESCRIPTION	QTY	ITEM	P/N	DESCRIPTION	QTY
1	1558	Hose Ftg, 1JS43 8-8	10	7	D0166	Cavity Plug XBOA-XXN	4
2	1559	Hose Ftg, 1J943 8-8	6	8	1552	Hose Ftg, 10L43-8-8	2
3	1554	Adapter, 8-F5OLO-S	12	9	C1123	Hose Clamp, 88 DB-20	2
4	D0165	Ftg Tee 8-R6LO-S	2	10	C4747	Ftg, Barb 2.00x45°	1
5	D0163	Valve, C-Bal Manifold	1	11	D1306	Adapter, 16-12 F50G5-S	1
6	D0549	Adapter, 16-8 F50G5-S	4	12	C4824	Hose Ftg, 1JS43 12-12	1

Controller Assembly

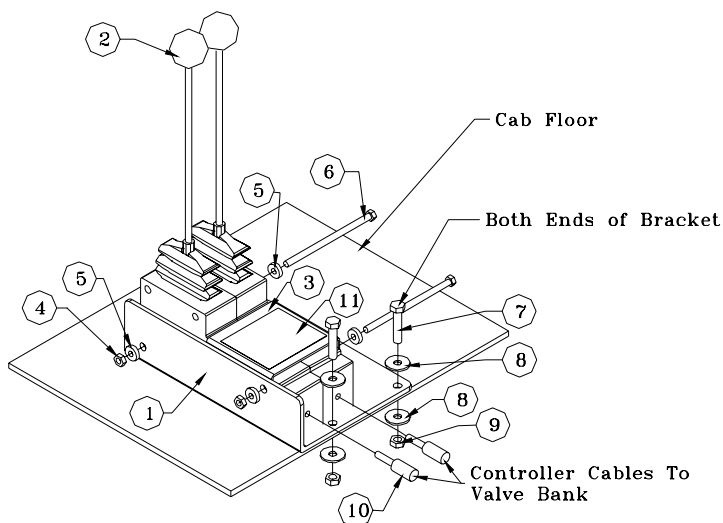

Controllers

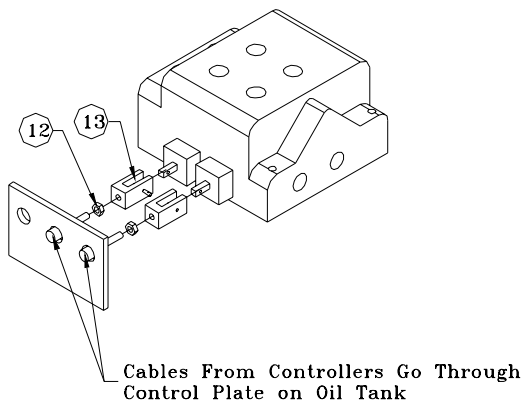

Valve Bank

ITEM	P/N	DESCRIPTION	QTY	ITEM	P/N	DESCRIPTION	QTY
1	2103	Bracket Controller	1	8	0343	Washer, 0.31 Flat	8
2	0608	Control Lever	2	9	0342	Nut, 0.31-18 Nyloc	4
3	0663	Bracket, Decal	1	10	0607	Controller Cable	2
4	0333	Nut, 0.25-20 Nyloc	2	11	0651	Decal, Operation	1
5	0340	Washer, 0.25 Flat	4	12	1056	Nut, 0.25 Fine Thread	2
6	0528	Cap Screw, 0.25-20x4.50	2	13	0662	Cable Ends, 0.25	2
7	0486	Cap Screw, 0.31-18x1.50	4				

Mounting Kit, 35 Gallon Tank

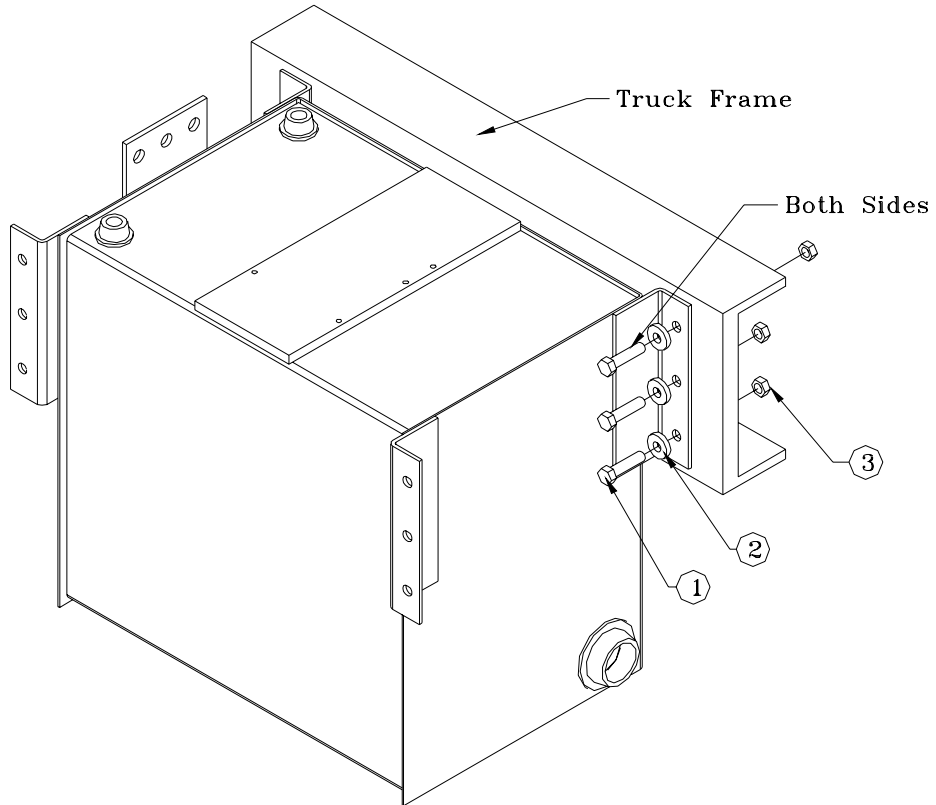

ITEM	P/N	DESCRIPTION	QTY
1	0501	Cap Screw, 0.50-13x2.00	6
2	0352	Washer, 0.50 Flat	6
3	0360	Nut, 0.50-13 Nyloc	6

Bumper Mounting

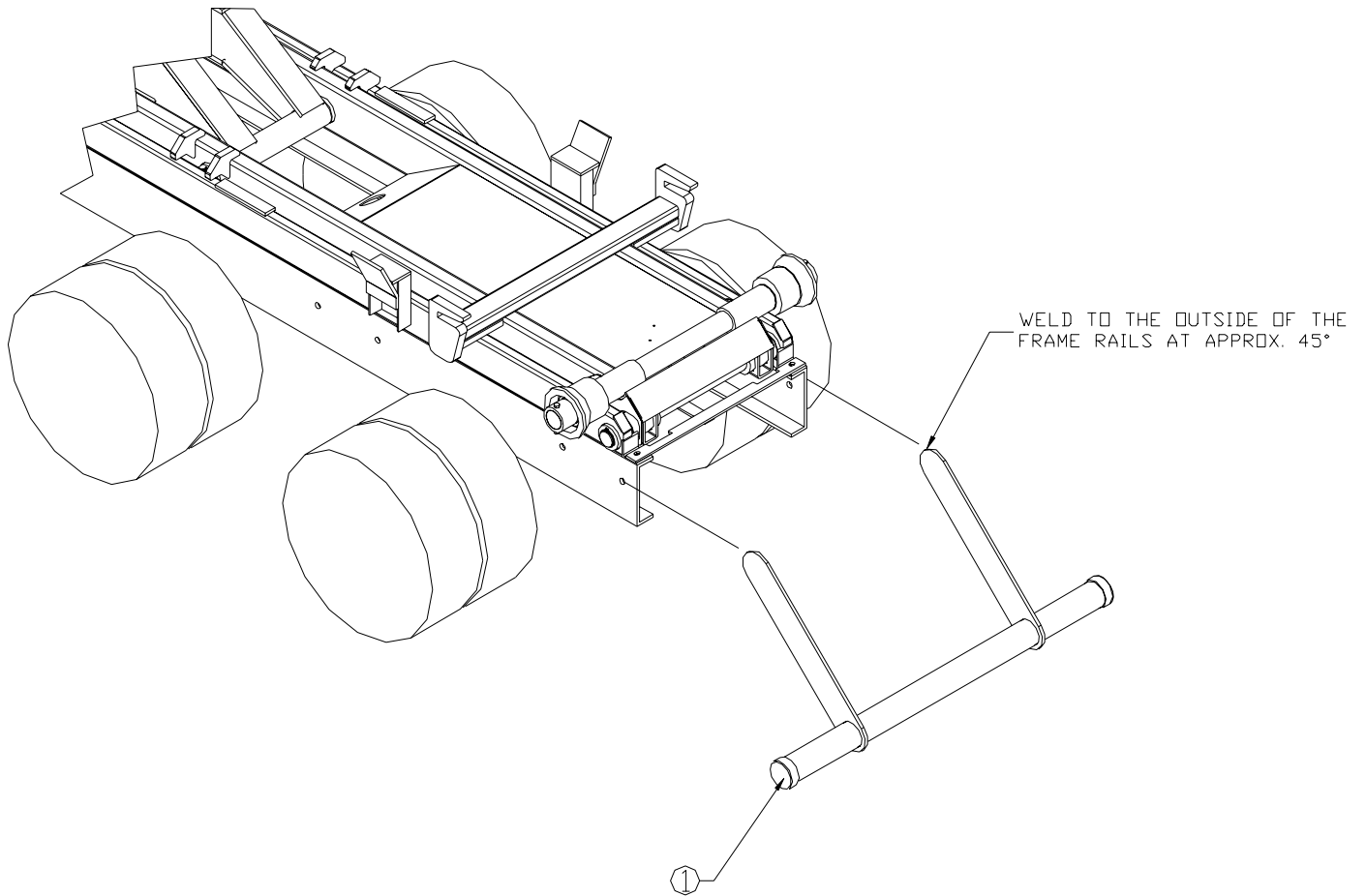

ITEM	P/N	DESCRIPTION	QTY
1	D0007	Bumper Assembly	1

Miscellaneous Parts

P/N	DESCRIPTION	QTY	P/N	DESCRIPTION	QTY
6900	Fender, Tandem	2	D0045	Alarm, Back Up	1
C6081	Tail Light, Combination	2	D0046	Bracket, License Plate	1
C6181	Light, Bar Red	1	D0047	Bracket, Clearance	4
D0043	Light, Rear Marker, W/ Reflector, Red	4	D0048	Bracket, Tail Light	2
D0044	Light, Clearance, W/Reflector, Amber	2			

Subframe

Minimum recommended rail construction per number of rear rollers on loader.		
	Single	Double
190-24-65	6x3x3/8 & 1/2x3 Plt	6x3x3/8 & 1/2x3 Plt

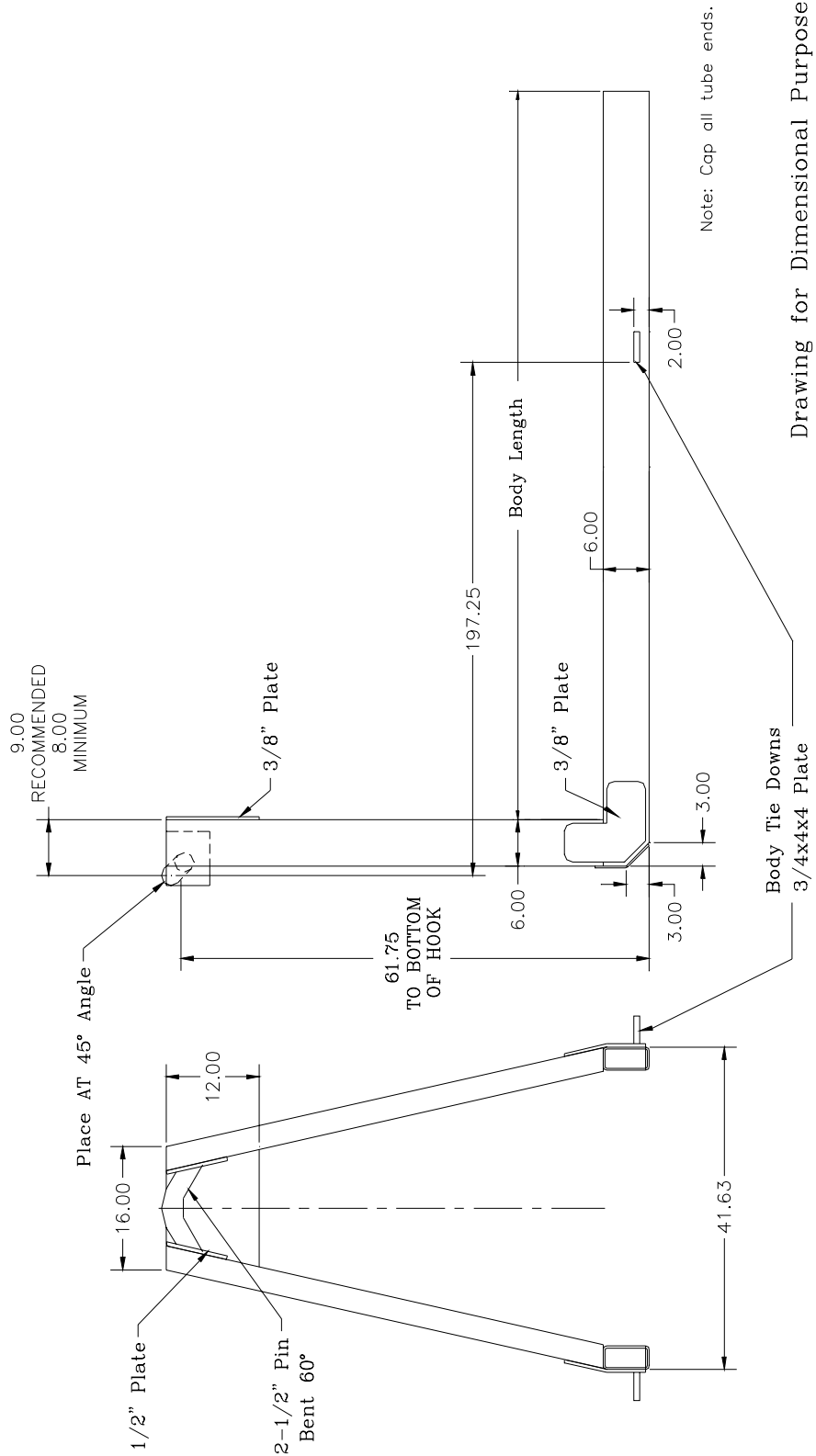

Drawing for Dimensional Purposes Only



Limited Warranty Statement

Stellar Industries, Inc. (Stellar) warrants products designed and manufactured by Stellar to be free from defects in material and workmanship under proper use and maintenance. Products must be installed and operated in accordance with Stellar's written instructions and capacities. The warranty period shall cover the following:

Twelve (12) month warranty on parts from the date recorded by Stellar as the in-service date, not to extend beyond twenty-four (24) months from date of manufacture,

Twelve (12) month repair labor from the date recorded by Stellar as the in-service date, not to extend beyond twenty-four (24) month from date of manufacture, and

Thirty-six (36) month warranty on all Stellar Crane and Hooklift structural parts from the date recorded by Stellar as the in-service date, not to extend beyond forty-eight (48) months from date of manufacture.

The in-service date will be derived from the completed warranty registration card. In the event a warranty registration card is not received by Stellar, the factory ship date will be used.

Stellar's obligation under this warranty is limited to, and the sole remedy for any such defect shall be, the repair and/or replacement (at Stellar's option) of the unaltered part and/or component in question. Stellar after-sales service personnel must be notified by telephone, fax, or letter of any warranty-applicable damage within fourteen (14) days of its occurrence. If at all possible, Stellar will ship the replacement part within 24-hours of notification by the most economical, yet expedient, means possible. Expedited freight delivery will be at the expense of the owner.

Warranty claims must be submitted and shall be processed in accordance with Stellar's established warranty claim procedure. Stellar after-sales service personnel must be contacted prior to any warranty claim. A return materials authorization (RMA) account number must be issued to the claiming party prior to the return of any warranty parts. Parts returned without prior authorization will not be recognized for warranty consideration. All damaged parts must be returned to Stellar freight prepaid; freight collect returns will be refused. Freight reimbursement of returned parts will be considered as part of the warranty claim.

Warranty service will be performed by any Stellar new equipment distributor, or by any Stellar-recognized service center authorized to service the type of product involved, or by the Stellar factory in the event of a direct sale. At the time of requesting warranty service, the owner must present evidence of date of delivery of the product. The owner shall be obligated to pay for any overtime labor requested of the servicing company by the owner, any field service call charges, and any towing and/or transportation charges associated with moving the equipment to the designated repair/service provider.

All obligations of Stellar and its authorized dealers and service providers shall be voided if someone other than an authorized Stellar dealer provides other than routine maintenance service without prior written approval from Stellar. In the case repair work is performed on a Stellar-manufactured product, original Stellar parts must be used to keep the warranty in force. The warranty may also be voided if the product is modified or altered in any way not approved, in writing, by Stellar.

The owner/operator is responsible for furnishing proof of the date of original purchase of the Stellar product in question. Warranty registration is the ultimate responsibility of the owner and may be accomplished by the completion and return of the Stellar product registration card provided with the product. If the owner is not sure of registration, he is encouraged to contact Stellar at the address below to confirm registration of the product in question. This warranty covers only defective material and workmanship. It does not cover depreciation or damage caused by normal wear and tear, accident, mishap, untrained operators, or improper or unintended use. The owner has the obligation of performing routine care and maintenance duties as stated in Stellar's written instructions, recommendations, and specifications. Any damage resulting from owner/operator failure to perform such duties shall void the coverage of this warranty. The owner will pay the cost of labor and supplies associated with routine maintenance.

The only remedies the owner has in connection with the breach or performance of any warranty on the Stellar product specified are those set above. In no event will Stellar, the Stellar distributor/dealer, or any company affiliated with Stellar be liable for business interruptions, costs of delay, or for any special, indirect, incidental, or consequential costs or damages. Such costs may include, but are not limited to, loss of time, loss of revenue, loss of use, wages, salaries, commissions, lodging, meals, towing, hydraulic fluid, or any other incidental cost.

All products purchased by Stellar from outside vendors shall be covered by the warranty offered by that respective manufacturer only. Stellar does not participate in, or obligate itself to, any such warranty.

Stellar reserves the right to make changes in design or improvement upon its products without imposing upon itself the same upon its products theretofore manufactured.

This warranty will apply to all Stellar Hooklifts, Stellar Service Trucks, & Truck-mounted Cranes shipped from Stellar's factory after July 1, 2005. The warranty is for the use of the original owner only and is not transferable without prior written permission from Stellar.

THIS WARRANTY IS EXPRESSLY IN LIEU OF ANY OTHER WARRANTIES, EXPRESS OR IMPLIED, INCLUDING ANY WARRANTY OF MERCHANTABILITY OR FITNESS FOR A PARTICULAR PURPOSE. REMEDIES UNDER THIS WARRANTY ARE LIMITED TO THE PROVISION OF MATERIAL AND SERVICES, AS SPECIFIED HEREIN. STELLAR INDUSTRIES, INC. IS NOT RESPONSIBLE FOR INCIDENTAL OR CONSEQUENTIAL DAMAGES.

Revision Date: February 2007

Document Number: 37040