



STELLAR SHUTTLE
MODEL 190-24-65 H
P/N (9030)
ASSEMBLY
AND
INSTALLATION
MANUAL

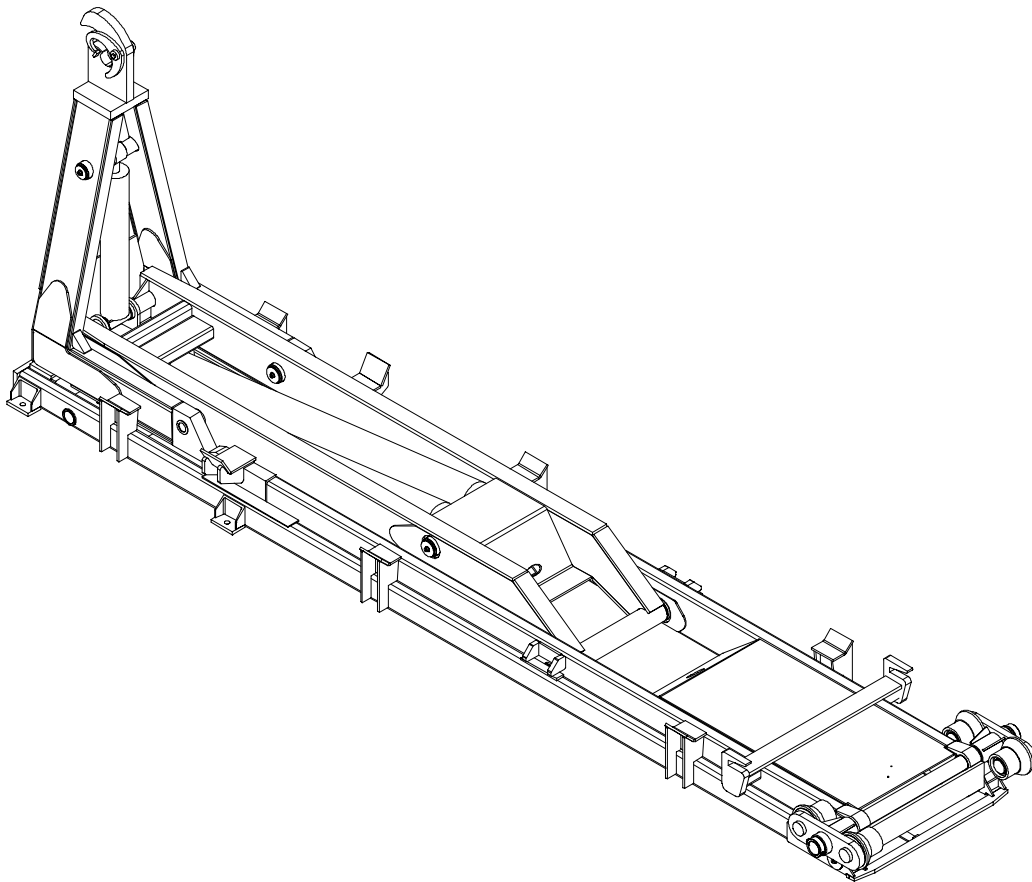

Table of Contents

Hydraulic Hook Lift Specifications	2
Base Assembly	3
Dump Assembly	4
Double Roller Assembly	5
Secondary Assembly	6
Tilt Assembly	7
Cylinder Assembly	8
Installation Instructions	9
Mounting Kit	10
Safety Valve Installation	11
Rotary Valve Installation	12
25 Gallon Hydraulic Assembly	13
25 Gallon Tank Assembly	14
Hose Kit	15
Controller assembly	16
Subframe	17
Warranty	18

Hydraulic Hook Lift Specifications

Lifting Capacity:	65,000 pounds gross weight evenly distributed in, or on, body.
Container Length:	19-foot through 24-foot from front A-frame to rear of skid rails. Longer bodies may be accommodated if full dump angle is not required (may require special body-mounted or extendable truck-mounted bumper to meet the Office of Motor Carrier Safety (OMCS) Rear End Protection regulation 393.86)
Maximum Dump Angle:	45°
Operating Pressure:	4200 PSI maximum
Weight of Loader:	Loader weight not to exceed 8,100 pounds
Height of Loader:	Loader height not to exceed 11.56" as measured from top of truck frame to top of loader rollers
Hook Height:	61.75-inches from bottom of skid rails to centerline of hook bar. Loader must be able to pick up 10-inches below grade when mounted on a truck with 41" frame height.
Hydraulic Pump:	Direct-coupled high-pressure gear pump.
Hydraulic Control Valve:	Stack-type valve mounted directly onto the oil reservoir.
Controls:	Dual manual levers with sealed cable actuators mounted in the truck cab to allow full feathering of all loader functions.
Tilting Hook Assembly:	Loader must have pivoting type front tilt section (jib) to provide a low degree loading/unloading angle. Hook to include automatic mechanical safety latch, which disengages only when the container/body is in proper position to be picked up or dropped off.
Tilt Cylinder:	Single 5-inch bore with 2.5-inch diameter rod cylinder. Cylinder must be double acting and include dual integral pilot-operated counterbalance valves to prevent cylinder collapse in case of hose failure.
Tilt Section Operation:	Loader must include a hydraulic lock-out device to prevent operation of the tilt section while loader is in the dumping mode.
Lift/Dump Cylinder:	Dual 7-inch bore with 3.0-inch diameter rod cylinder. Cylinder must be double acting and include dual integral pilot-operated counterbalance valves to prevent cylinder collapse in case of hose failure.
Dump/Tilt Interlock:	Dumping must be accomplished through a rear pivot. Tilt and lift sections must lock into a rigid full length 34" wide frame with front saddles to provide support for the container while in the dump mode. These sections form this frame without the use of mechanical latches, which rely on gravity, springs, or container/body mounted latches.
Rear Body Hold-Downs:	Dual fixed-position hold-down devices mounted to the dump frame to secure the body to the loader through all ranges of the dump mode. This must be accomplished without the use of steel springs and/or hydraulic/air cylinders.
Rear Dump Hinge Pin:	3-inch diameter stainless steel minimum
Pins & Bushings	All pins to be stainless steel. All bushings to be of the permanently lubricated variety. No grease zerks allowed.
Hoses & Hydraulic Fittings:	All hoses and fittings are to be SAE: metrics not allowed. O-ring face seal fittings to be utilized wherever possible.
Origin of Manufacture:	Loader to be designed and manufactured in the United States of America.

Base Assembly P/N 16705

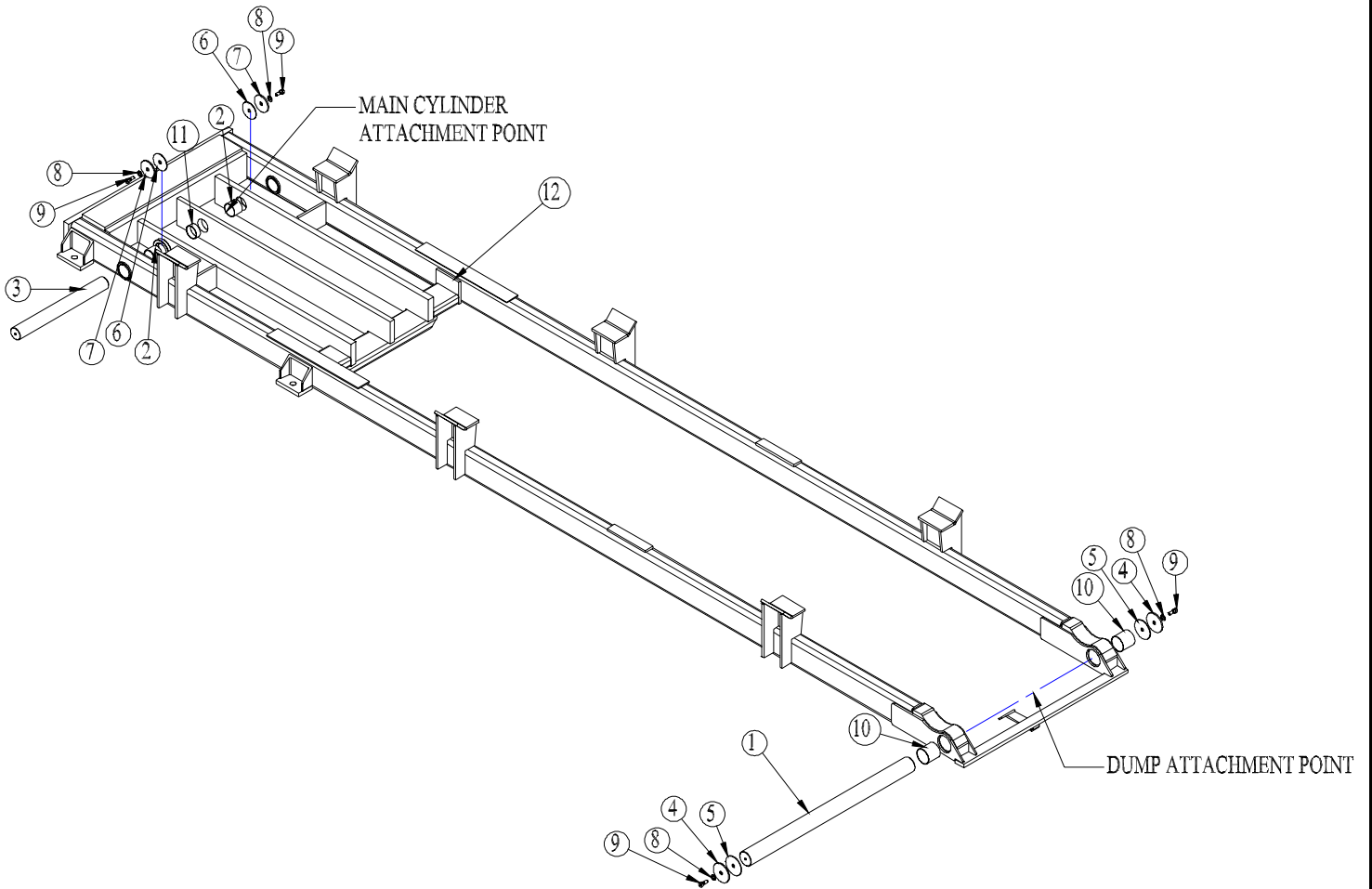

ITEM	PART	DESCRIPTION	QTY.
1	9224	PIN 3.00X43.00 D&T	1
2	0635	BUSHING 40DXR32 GARLOCK	2
3	9300	PIN 2.50X23.25 D&T	1
4	8597	PIN CAP 0.69x4.00x0.25 SS	2
5	12922	THRUST WASHER 0.64x4.00x0.125	2
6	12921	THRUST WASHER 0.64x3.50x0.125	2
7	8455	PIN CAP 0.69X3.50X0.25 SS	2
8	12711	THRUST WASHER 0.63 DIA	4
9	12673	CAP SCREW 0.50-13 SHOULDER	4
10	2227	BUSHING 48DXR48 GARLOCK	2
11	13343	BUSHING 40DXR16 2.50X1.00 GARLOCK	1
12	9294	BASE 190-24-65	1

Dump Assembly P/N 16706

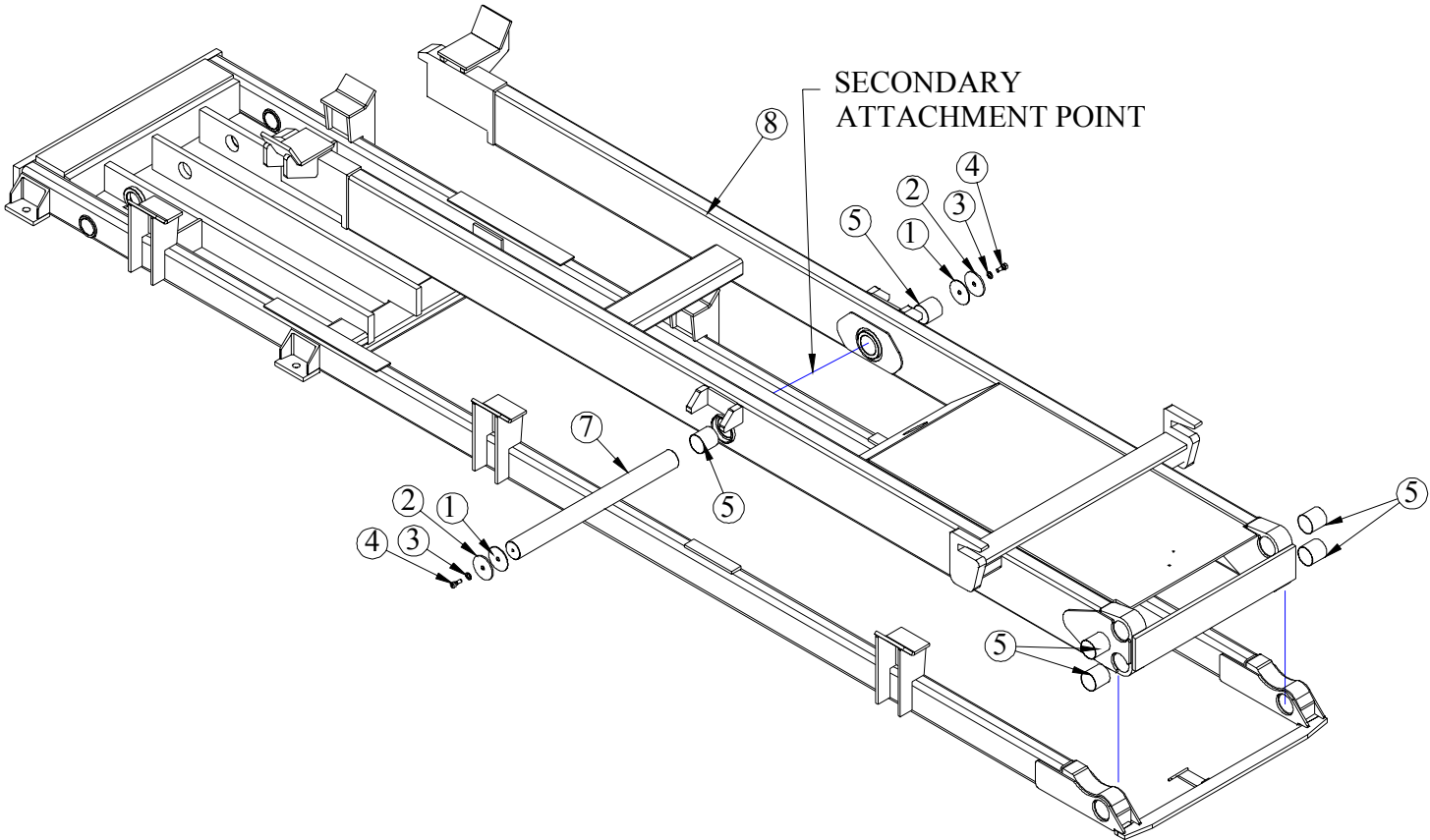

ITEM	PART	DESCRIPTION	QTY.
1	12922	THRUST WASHER 0.64x4.00x0.125	2
2	8597	PIN CAP 0.69x4.00x0.25 SS	2
3	12711	THRUST WASHER 0.63 DIA	2
4	12673	CAP SCREW 0.50-13 SHOULDER	2
5	2227	BUSHING 48DXR48 GARLOCK	6
7	9225	PIN 3.00X33.75 D&T	1
8	9108	DUMP 190-24-65 H	1

Double Roller Assembly P/N 16622

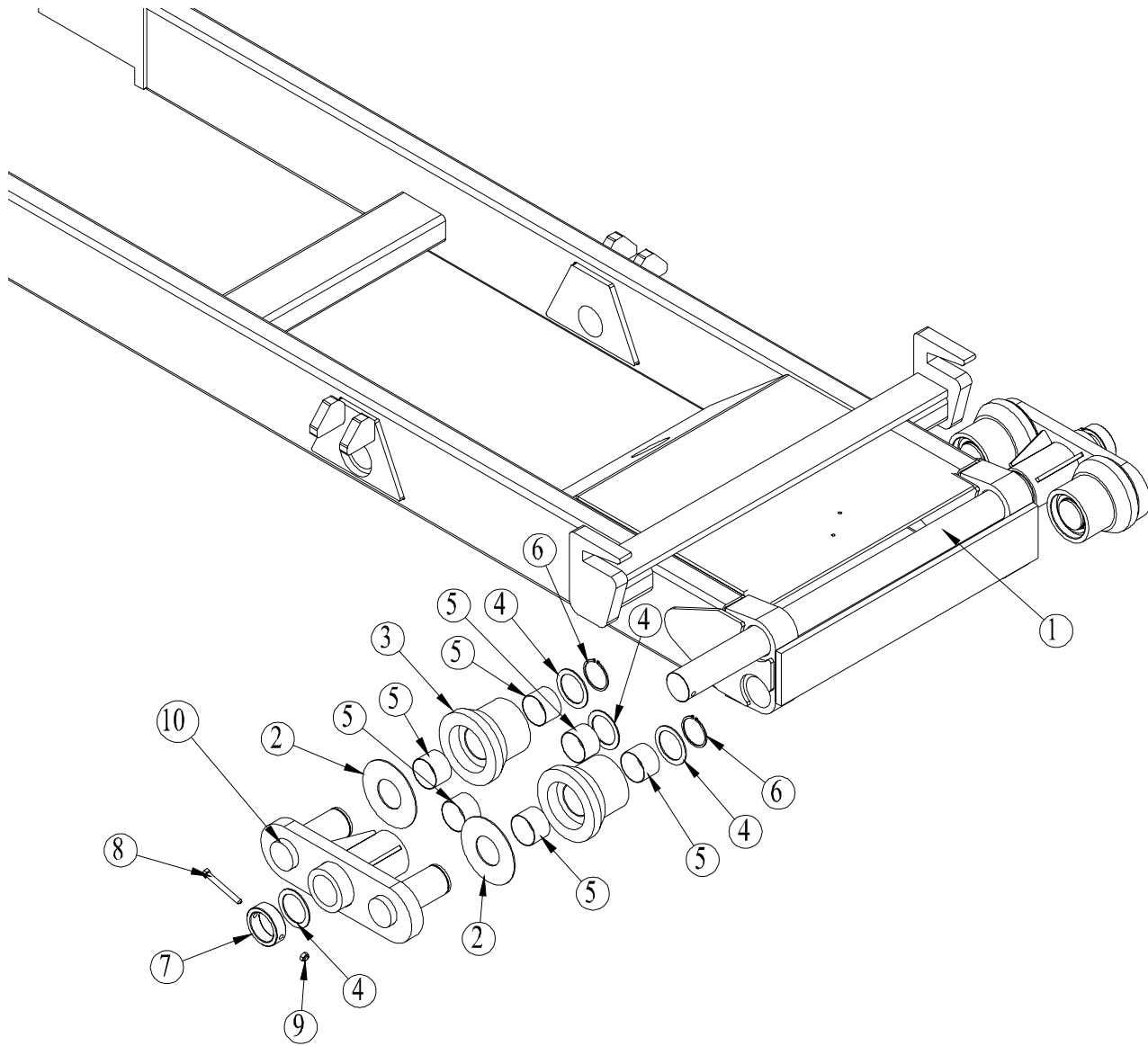

ITEM	PART	DESCRIPTION	QTY.
1	2719	PIN 3.00X56.00	1
2	3798	WASHER 3.06X7.00X0.13 UHMW	4
3	2715	ROLLER	4
4	1548	THRUST WASHER 3.01DIA UHMW .12 THK	8
5	0865	BUSHING 48DXR32 GARLOCK	12
6	2096	SNAP RING 3.00	4
7	2727	COLLAR RETAINER	2
8	0507	CAP SCR 0.50-13X4.50 HHGR5	2
9	C6106	NUT 0.50-13 HHGR5 NYLOC	2
10	3315	ROLLER DOUBLE	2
11			

Secondary Assembly P/N 16650

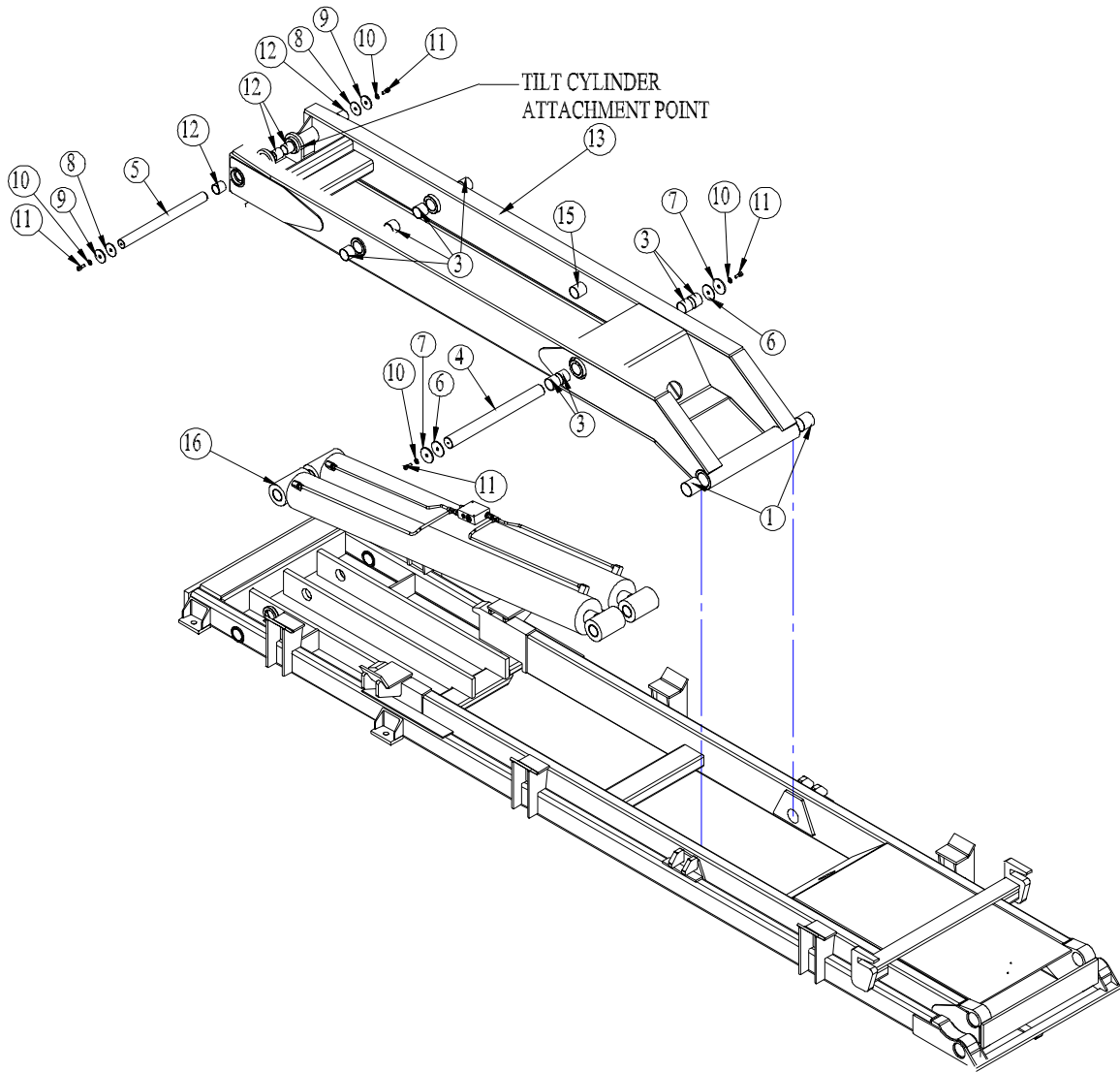

ITEM	PART	DESCRIPTION	QTY.
1	2227	BUSHING 48DXR48 GARLOCK	2
3	0635	BUSHING 40DXR32 GARLOCK	8
4	4437	PIN 2.50X27.50	1
5	9718	PIN 2.00X24.75 D&T	1
6	12921	THRUST WASHER 0.64x3.50x0.125	2
7	8455	PIN CAP 0.69X3.50X0.25 SS	2
8	12719	THRUST WASHER 0.64x3.00x0.125	2
9	8454	PIN CAP 0.69x3.00x0.25 SS	2
10	12711	THRUST WASHER 0.63 DIA	4
11	12673	CAP SCREW 0.50-13 SHOULDER	4
12	4381	BUSHING 32DXR32 2.00X2.00 GARLOCK	4
13	9143	SECONDARY 174-20-65	1
15	17320	BUSHING 40DXR40 GARLOCK	1
16	19070	CYLINDER ASM 190-24-65	1

Tilt Assembly P/N 16707

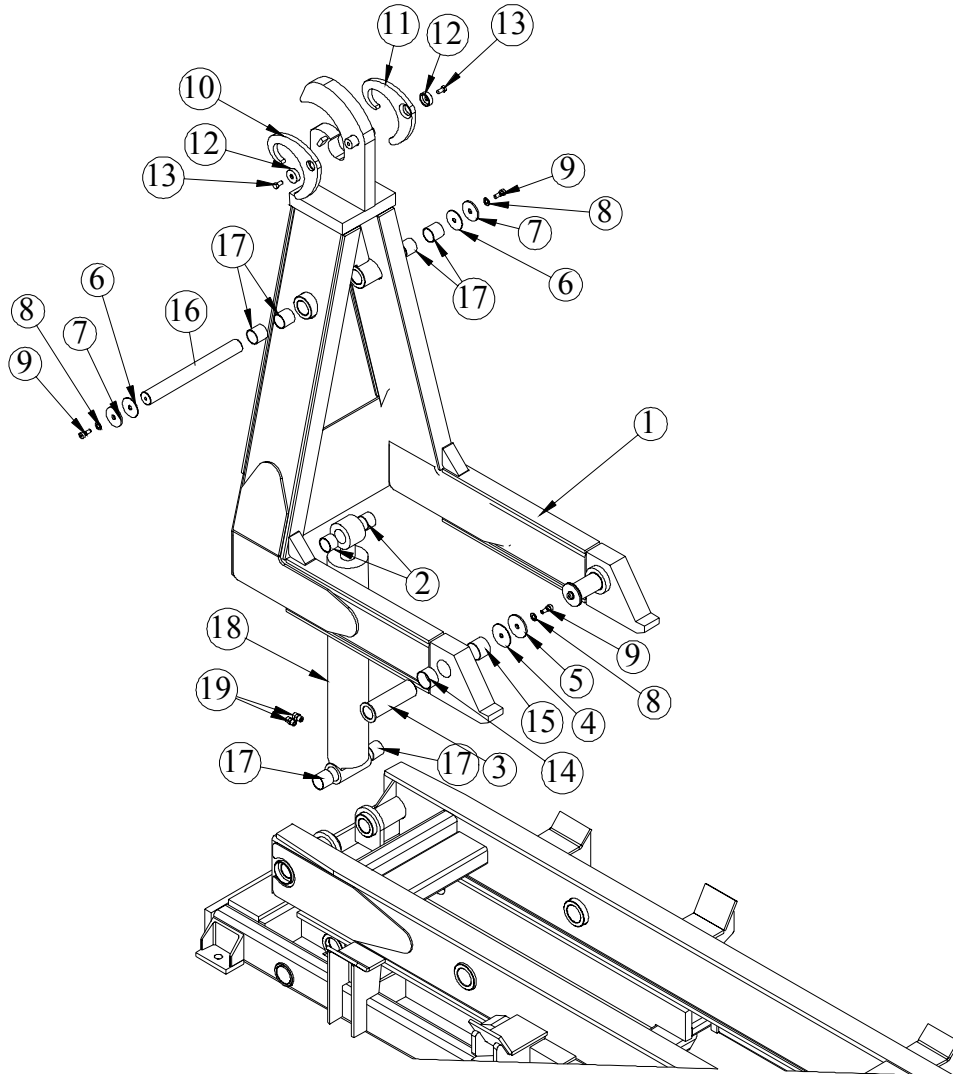

ITEM	PART	DESCRIPTION	QTY.
1	8600	TILT 190-24-65 H	1
2	4380	BUSHING 32DXR24 2.00X1.50 GARLOCK	2
3	8598	PIN WLDMT 2.50X8.38 D&T	2
4	12921	THRUST WASHER 0.64x3.50x0.125	2
5	8455	PIN CAP 0.69X3.50X0.25 SS	2
6	12719	THRUST WASHER 0.64x3.00x0.125	2
7	8454	PIN CAP 0.69x3.00x0.25 SS	2
8	12711	THRUST WASHER 0.63 DIA	4
9	12673	CAP SCREW 0.50-13 SHOULDER	4
10	2898	HOOK LATCH SS	1
11	2899	HOOK LATCH CS	1
12	8818	PIN CAP 0.63X2.00X0.63	2
13	8457	CAP SCR 0.50-13X1.00 SS	2
14	13817	BUSHING 40DXR24 2.50X1.50 GARLOCK	2
15	0635	BUSHING 40DXR32 GARLOCK	2
16	9292	PIN 2.00X18.25 D&T	1
17	4381	BUSHING 32DXR32 2.00X2.00 GARLOCK	6
18	3488	CYLINDER 5.00X22.50	1
19	1554	FTG ADAPT 8-F5OLO-S	2

Cylinder Assembly P/N 19070

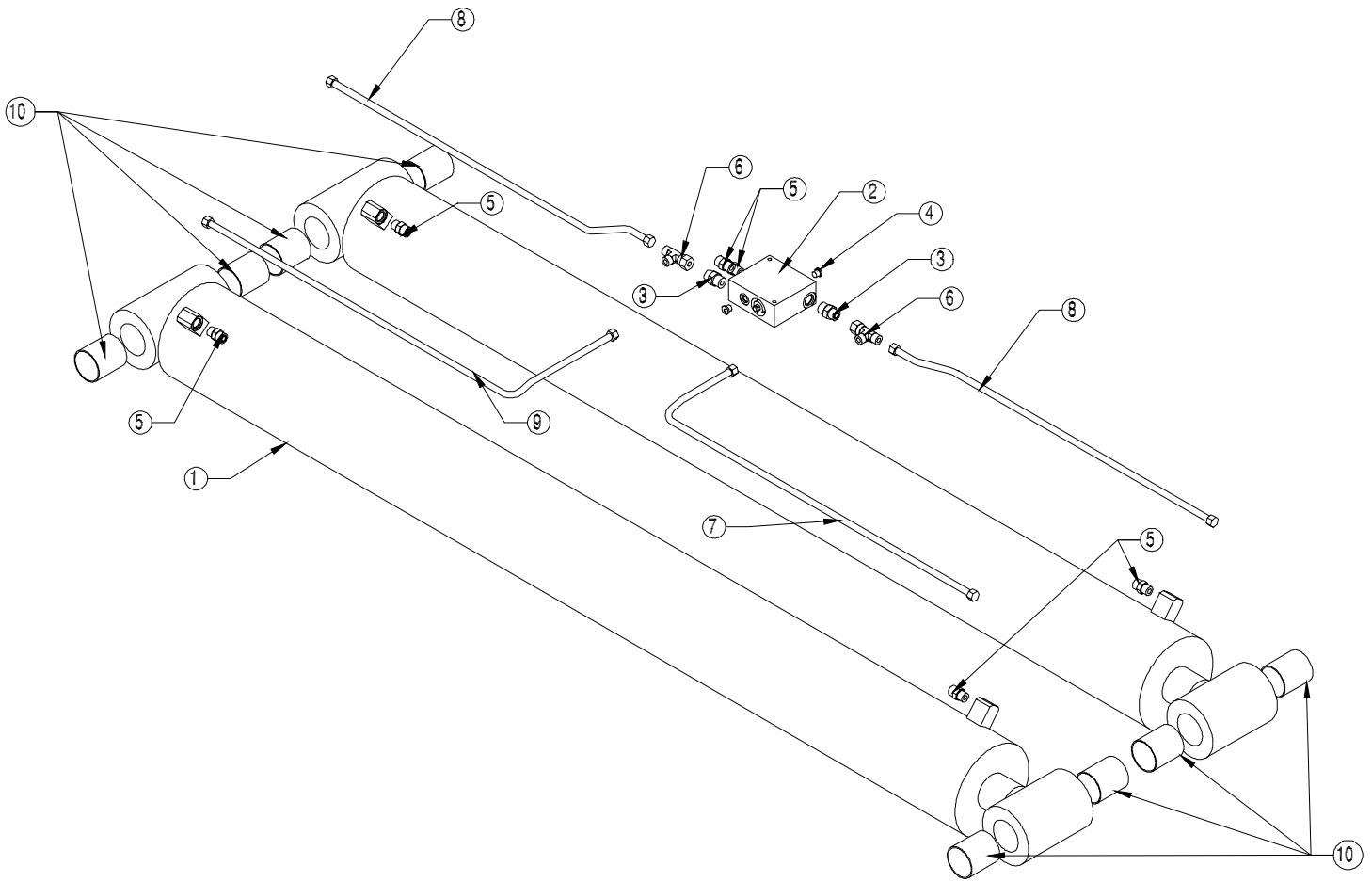

NO.	PART NO.	DESCRIPTION	QTY.
1	0811	CYLINDER 7.00X71.63	2
2	15995	MANIFOLD ASM DUAL T2A 5000PSI	1
3	C2252	FTG ADAPT 8-10-F5OLO-S	2
4	C4961	PLUG STR HOLLOW HEX 0.38 6-HP5ON	2
5	1554	FTG ADAPT 8-F5OLO-S	6
6	D0165	FTG TEE 8-R6LO-S	2
7	19141	TUBE ASM 0.50 X 33.38 RET	1
8	19069	TUBE ASM 0.50 X 32.50	2
9	19068	TUBE ASM 0.50 X 33.38 EXT	1
10	5739	BUSHING 40DXR48 GARLOCK	8

INSTALLATION INSTRUCTIONS

(SEE DIAGRAM ON PAGE 10)

READ ALL INSTRUCTIONS BEFORE PROCEEDING

MOUNT PTO AND PUMP

MOUNT RESERVOIR VALVE COMBO TO TRUCK FRAME

CONNECT SUCTION AND PRESSURE TO TANK, VALVE BANK, AND PUMP
FILL OIL RESERVOIR TO 3" OF THE TOP (MOBIL DTE 13M IS RECOMMENDED)

INSTALL CONTROLLERS AND CABLES IN CAB

SET SHUTTLE ON THE TRUCK SO THAT ITS FRONT PLATE IS AT LEAST 3" BEHIND THE CAB. THE SHUTTLE SHOULD BE SET A MINIMUM OF ½" ABOVE THE TRUCK FRAME

SQUARE THE SHUTTLE ON THE TRUCK FRAME

SHORTEN THE TRUCK FRAME SO THAT IT IS FLUSH WITH THE REAR OF THE LOADER **(IF FRAME IS NOT FLUSH, THE ROLLER ASSEMBLY WILL BE DAMAGED)**

WELD THE TWO SMALL MOUNTING CHANNELS (ITEM 2) TO THE BASE OF THE LOADER BETWEEN THE EXISTING TIE DOWNS (MAKE SURE THE AREA BELOW ON THE TRUCK FRAME IS FREE FROM OBSTRUCTIONS). USING 1" BOLTS (3 ½" LONG), WASHERS AND NUTS, ATTACH THE 6 MOUNTING CHANNELS (ITEM 1) TO THE 6 MOUNTS ON THE LOADER

USING THE MOUNTING CHANNELS AS A GUIDE DRILL (12) 1-1/16" HOLES THROUGH THE TRUCK FRAME

LOCATE (4) 6X4X1/2 ANGLES (ITEM 7). CLAMP THE SMALL FLANGE OF THE ANGLES TO THE BASE OF THE LOADER, THE REAR ANGLES SHOULD BE PLACED 1 INCH FORWARD FROM THE REAR OF THE LOADER. THE OTHER TWO CAN BE PLACED IN THE APPROXIMATE POSITIONS SHOWN ON PAGE 9.

DRILL (3) 1-1/16" HOLES PER ANGLE THROUGH THE LARGE FLANGE AND THE TRUCK FRAME. INSTALL 1" BOLTS (3" LONG), WASHERS AND NUTS AND SECURE TO THE TRUCK FRAME. THEN WELD THE ANGLES DIRECTLY TO THE BASE SECTION OF THE LOADER. THE ANGLES SHOULD HOLD THE BASE A MINIMUM OF ½" ABOVE THE TRUCK FRAME.

USING 1" BOLTS (3" LONG), WASHERS, AND NUTS SECURE ALL TIE DOWNS TO THE TRUCK FRAME AND THE LOADER

CONNECT HOSES TO VALVE BANK AS INDICATED IN HYDRAULIC ASSEMBLY

SET THE RELIEF VALVE TO 4200 PSI

OPERATE THE LOADER TO ELIMINATE AIR FROM THE SYSTEM

CHECK THE OIL LEVEL AND ADD OIL IF REQUIRED

Mounting Kit P/N 16561

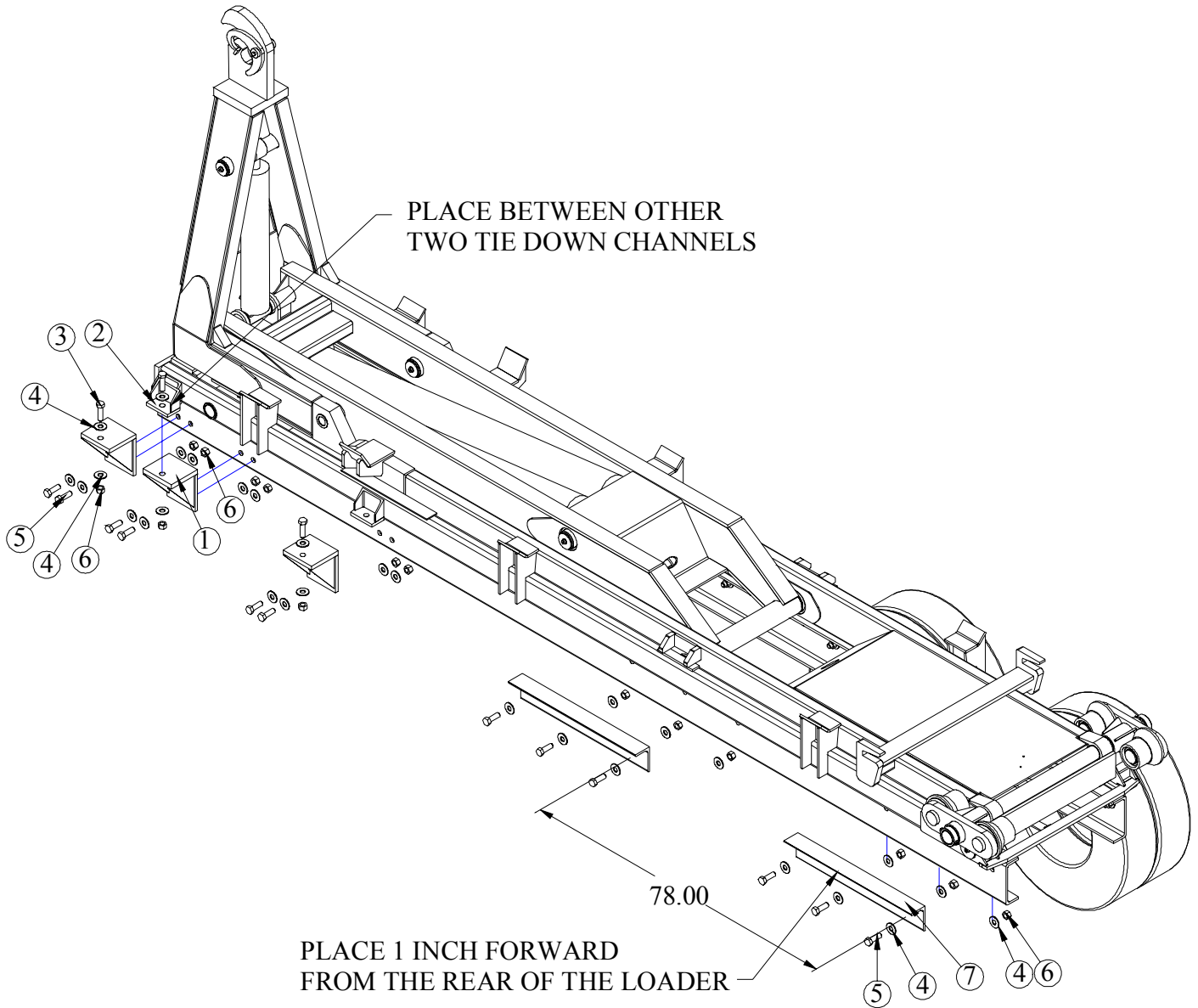

ITEM	PART	DESCRIPTION	QTY.
1	2891	TIE DOWN 65,000	6
2	2874	TIE DOWN 65,000	2
3	2830	CAP SCR 1.00-8X3.50 HHGR5	6
4	1443	WASHER 1.00 USS FLAT ZINC	60
5	1442	CAP SCR 1.00-8X3.50 HHGR5	24
6	0991	NUT 1.00 HH NYLOC	30
7	3238	ANGLE 4.00X6.00X.50WX36.00	4

Safety Valve Installation

Incorporated into the standard Stellar Hooklift is a safety valve designed to protect the dump section tabs from being damaged by the tilt section.

It is important to locate this valve properly for safe operation of the Stellar Hooklift.

This cartridge is located in the main valve stack and **MUST** be placed off of the tilt cylinder retract port. The following illustrations show a standard (driver side) installation and an optional (passenger side) installation.

Passenger side installations are common when mounting to cab-over chassis. All valve stacks are shipped for standard (driver side) installations. The safety valve must be moved to the tilt cylinder retract port for all non-standard installations. This valve will be switched with a load check plug when being moved to an alternate position. A poppet and spring are located behind the safety valve and load check plugs. Care should be taken not to lose these parts when modifying.

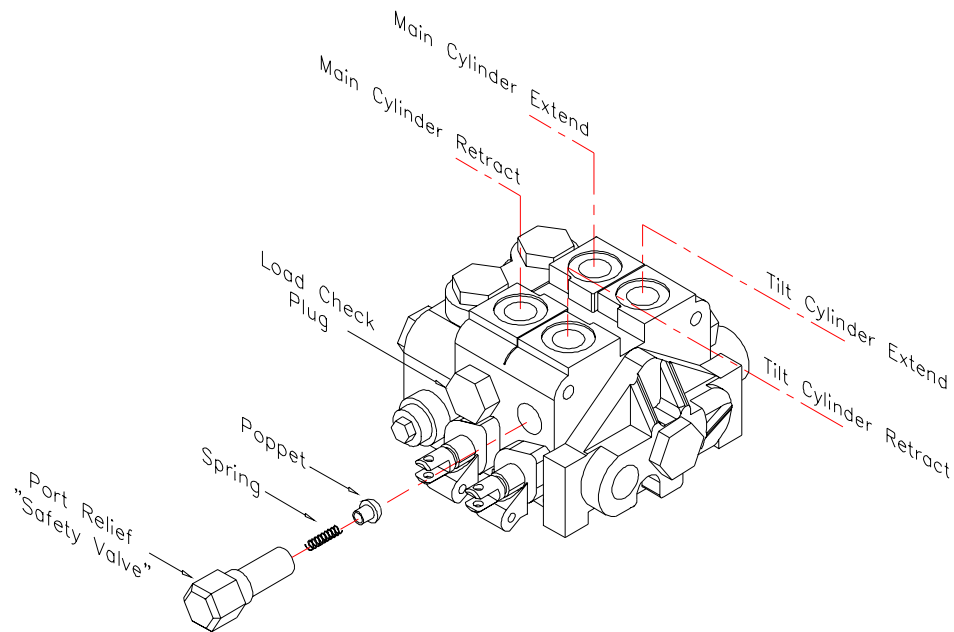

Valve stack for standard installation

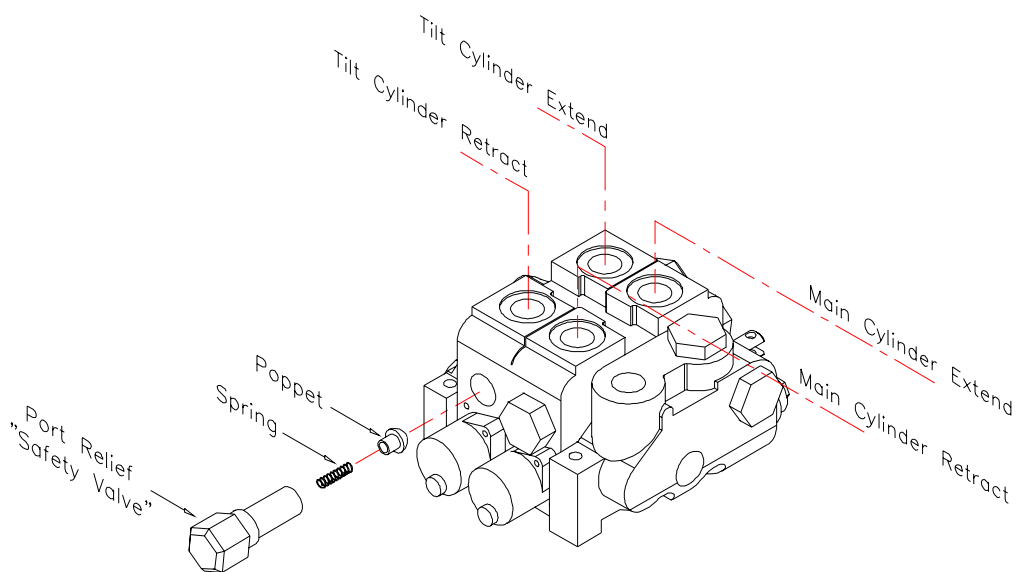

Valve stack for non-standard installation

Rotary Valve Installation

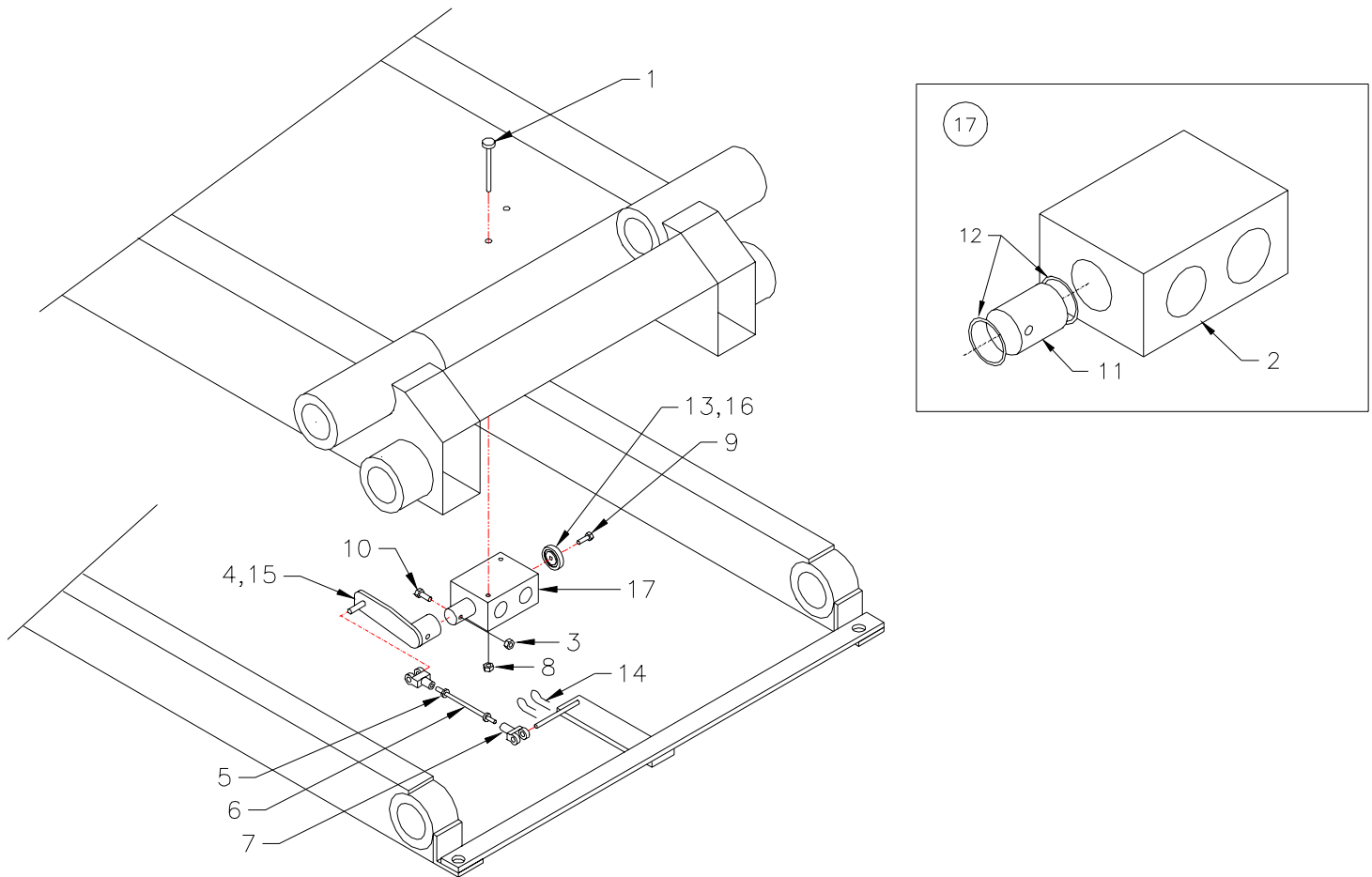

ITEM	P/N	DESCRIPTION	QTY	ITEM	P/N	DESCRIPTION	QTY
1	0482	Cap Screw, 0.25-20x3.00	2	10	0353	Cap Screw, 0.38-16x2.00	1
*2	0933	Body, Rotary Valve	1	*11	D0270	Spool, Rotary Valve	1
3	0347	Nut, 0.38-16 Nyloc	1	*12	0979	Seal, U-Cup	2
4	1521	Rod, Rotary Valve	1	13	3748	Washer, Rotary Valve	1
5	2478	Nut, 0.31-24	2	14	C6113	Cotter, 0.094x1.00	2
6	2476	Rod, 0.31-24 Threaded GR7	12"	15	0977	O'Ring, 1.00x1.25x0.12	1
7	2479	Clevis, 0.31 Pin	2	16	D1638	O'Ring, 1.12x1.38x0.12	1
8	0333	Nut, 0.25-20 Nyloc	2	17	0877	Rotary Valve Assembly	1
9	0480	Cap Screw, 0.25-20x1.00	1				

* Items are part of #17(0877- Rotary Valve Assembly)

25 Gallon Hydraulic Assembly P/N 17541

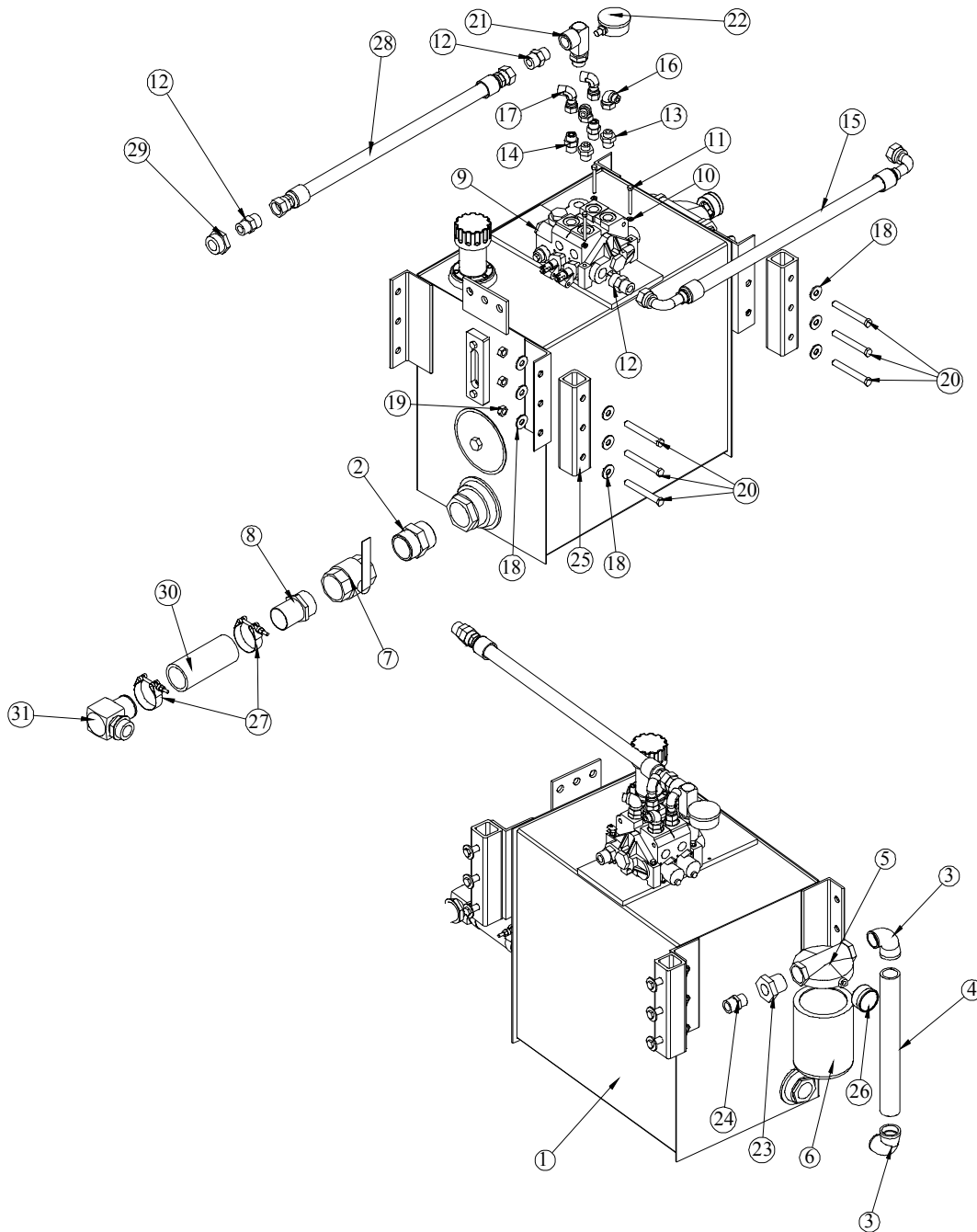

ITEM NO.	PART NO.	DESCRIPTION	QTY.	ITEM NO.	PART NO.	DESCRIPTION	QTY.
1	15468	RSRVR ASM 25GAL	1	17	C2376	FTG ADAPT 8-C6LO-S	2
2	7353	NIPPLE 2.00 HEX PIPE 2FF	1	18	0352	WASHER 0.50 USS FLAT ZINC	12
3	C4694	ST EL 1.25 90 DEG BLK	2	19	C6106	NUT 0.50-13 HHGR5 NYLOC	6
4	D0024	NIPPLE 1.25X14.00 BLK	1	20	0506	CAP SCR 0.50-13X4.00 HHGR5	6
5	C6228	FILTER HEAD SF120-25 1.3	1	21	14631	FTG MSTR/FSTR 90 12-12 HOOKLIFT	1
6	C6225	FILTER LARGE SE-10	1	22	10094	GAUGE OIL LF 2.5" 0-500 BM	1
7	C4750	VALVE BALL 2.00	1	23	C2375	FTG REDU 0102-20-12	1
8	C4730	FTG HOSE BARB 2.00	1	24	C4952	FTG ADAPT 12 FLO-S	1
9	2380	VB 2 SECT GRESEN V20	1	25	13325	SPACER TANK MOUNTING 25 GAL	2
10	0521	WASHER 0.25 LOCK	3	26	16145	GAUGE PRES FILTER SERVICE CI20	1
11	0339	CAP SCR 0.25-20X2.50 HHGR5	3	27	C4819	HOSE CLAMP 2.00	2
12	C2142	FTG ADAPT ML O'RING/ML 12-F5OLO-S	3	28	17903	HOSE 0.75(381-JC-JC-12-12-12-120)	1
13	C1855	FTG ADAPT 6-10 F5OLO-S	2	29	D1311	FTG ADAPT MSTR/FSTR 20-12F5OGS	1
14	C2252	FTG ADAPT 8-10-F5OLO-S	2	30	17766	HOSE SUCT 2.00 10FT	1
15	15467	HOSE 0.75(381-J9-J9-8-8-24)	1	31	17768	FTG 90 BARB/MSTR 4601-32-20	1
16	C2248	FTG ADAPT 6-C6LO-S	2				

25 Gallon Tank Assembly P/N 15468

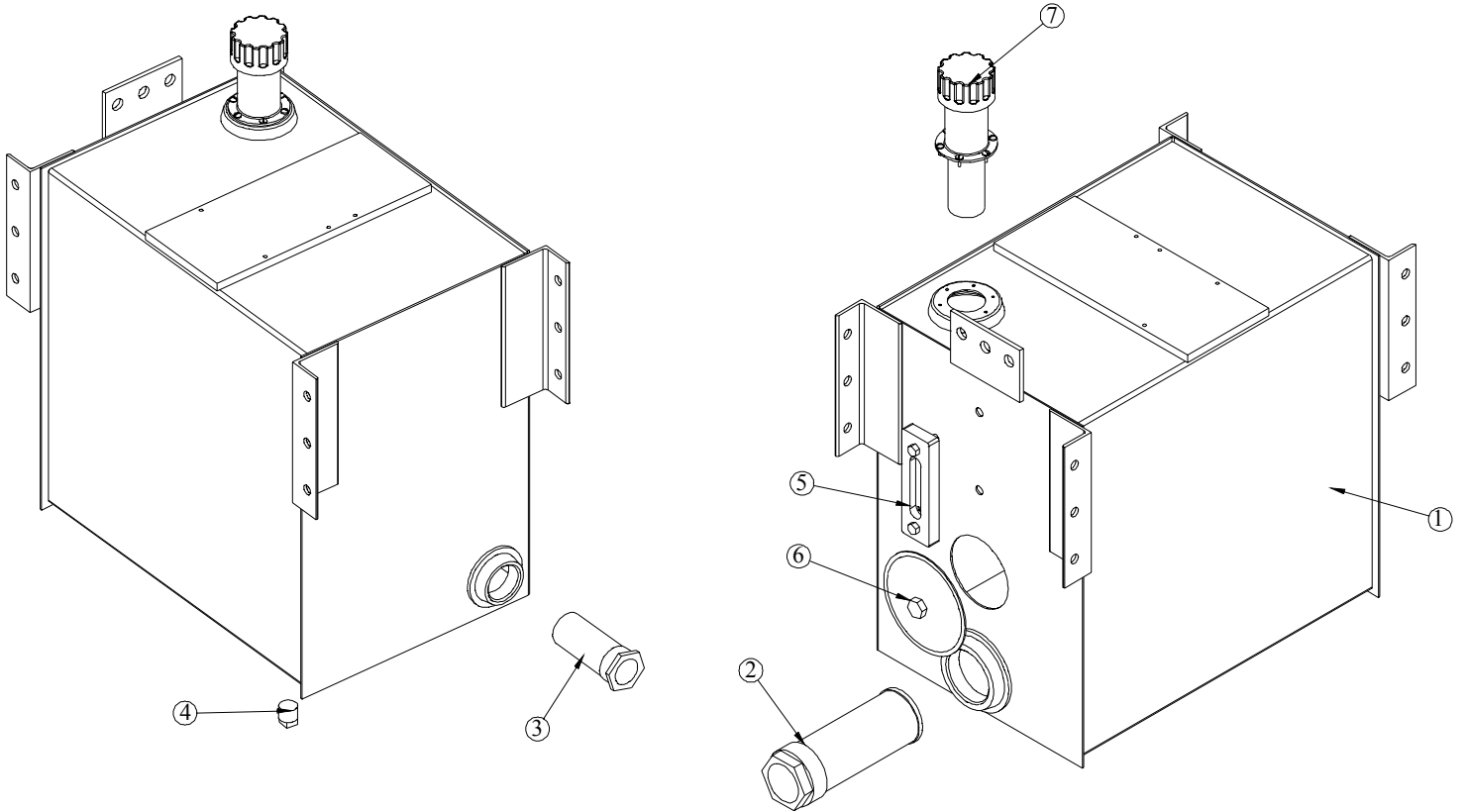

ITEM NO.	PART NO.	DESCRIPTION	QTY.
1	15461	OIL TANK 25GAL	1
2	C6327	FIL TER STRAINER 35GAL TF-2030	1
3	C6328	DIFFUSER 25-35GAL	1
4	C2126	MAGNETIC PLUG DRAIN 3/4"	1
5	15463	THERMO SIGHT GAUGE	1
6	15464	TANK COVER	1
7	15462	CAP FILL ASM W/3" NECK	1

Hose Kit

P/N 16708

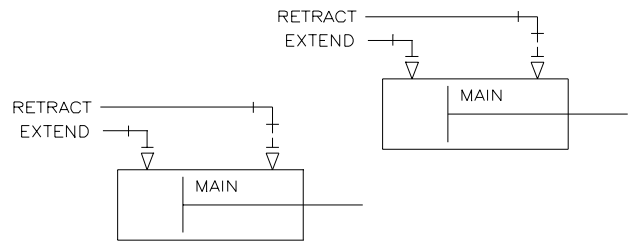
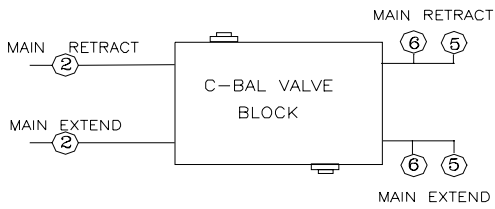
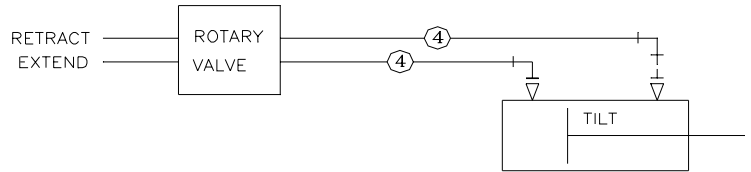
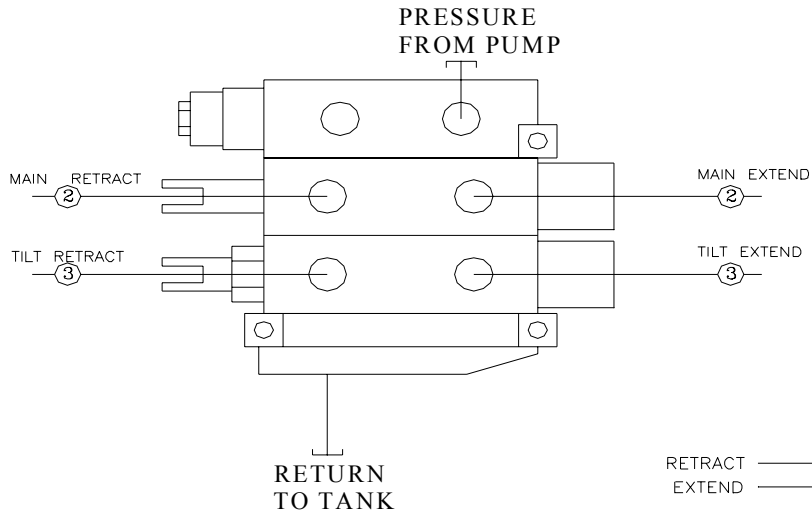

ITEM	PART#	DESCRIPTION	QTY
1	16708	HOSE KIT 190-24-65	1 (ITEMS 2-6)
2	16625	HOSE .50 X 90.00	2
3	15812	HOSE .38 X 252.00	2
4	18706	HOSE .38 X 248.00	2
5	16701	HOSE .50 X 30.00	2
6	16700	HOSE .50 X 30.00	2

Controller Assembly

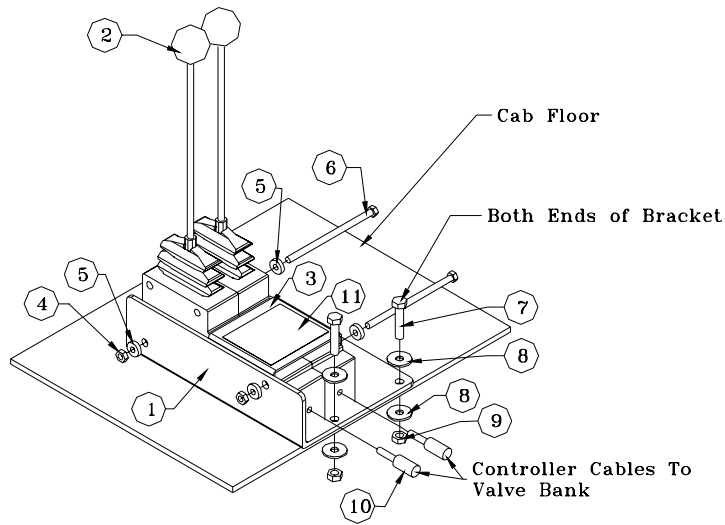

Controllers

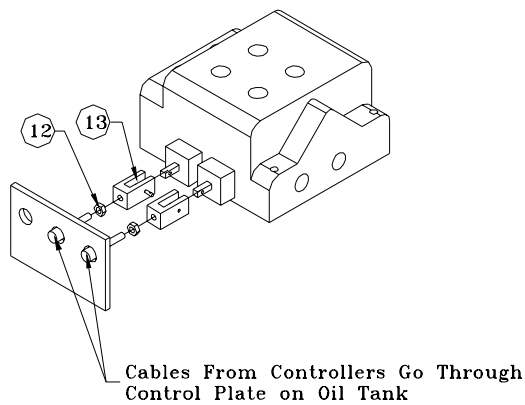

Valve Bank

ITEM	P/N	DESCRIPTION	QTY	ITEM	P/N	DESCRIPTION	QTY
1	2103	Bracket Controller	1	8	0343	Washer, 0.31 Flat	8
2	0608	Control Lever	2	9	0342	Nut, 0.31-18 Nyloc	4
3	0663	Bracket, Decal	1	10	0607	Controller Cable	2
4	0333	Nut, 0.25-20 Nyloc	2	11	0651	Decal, Operation	1
5	0340	Washer, 0.25 Flat	4	12	1056	Nut, 0.25 Fine Thread	2
6	0528	Cap Screw, 0.25-20x4.50	2	13	0662	Cable Ends, 0.25	2
7	0486	Cap Screw, 0.31-18x1.50	4				

Subframe

Minimum recommended rail construction per number of rear rollers on loader.		
	Single	Double
190-24-65	6x3x3/8 & 1/2x3 Plt	6x3x3/8 & 1/2x3 Plt

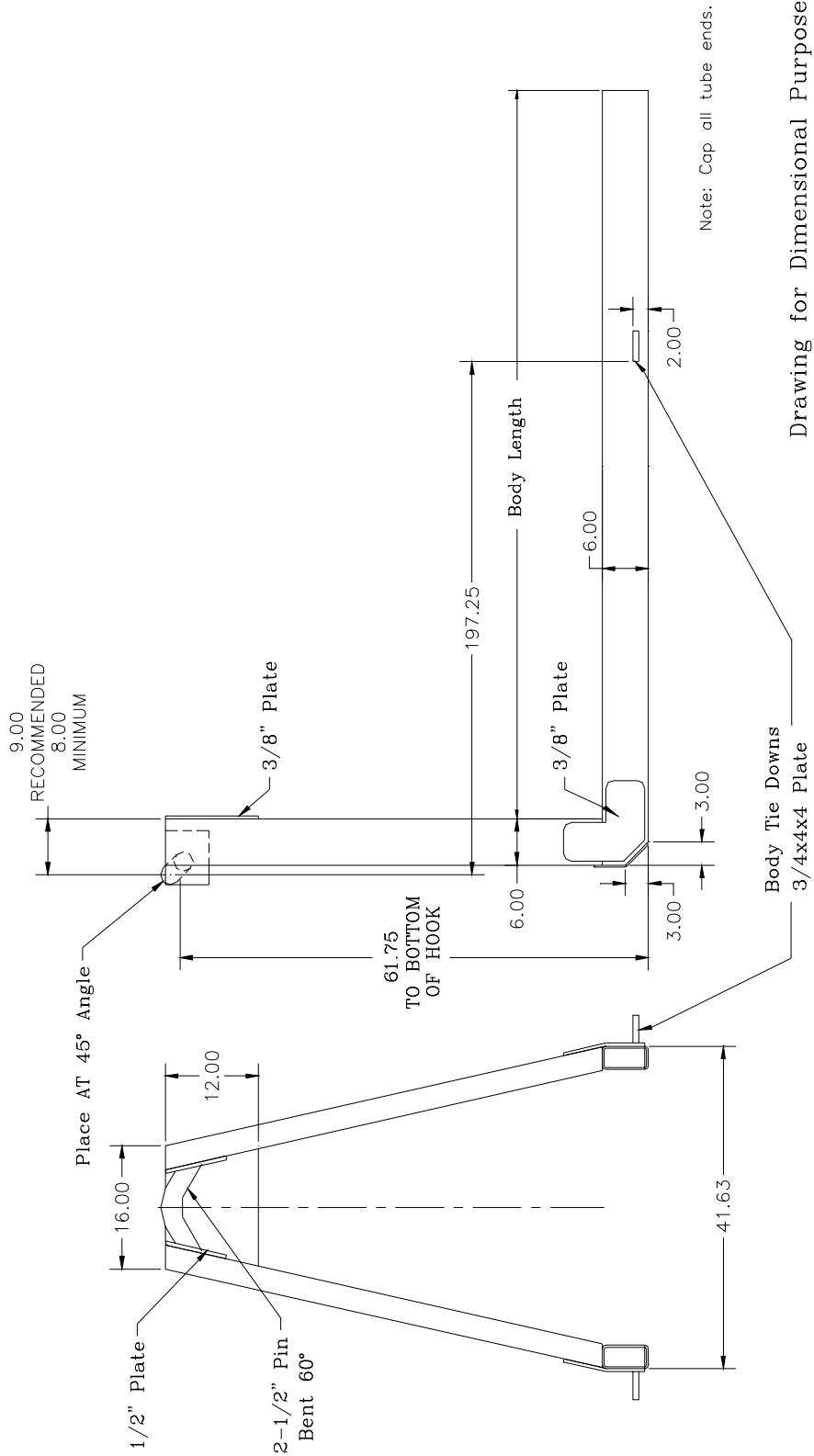

Drawing for Dimensional Purposes Only



Limited Warranty Statement

Stellar Industries, Inc. (Stellar) warrants products designed and manufactured by Stellar to be free from defects in material and workmanship under proper use and maintenance. Products must be installed and operated in accordance with Stellar's written instructions and capacities. The warranty period shall cover the following:

- Twelve (12) month warranty on parts from the date recorded by Stellar as the in-service date, not to extend beyond twenty-four (24) months from date of manufacture,
- Twelve (12) month repair labor from the date recorded by Stellar as the in-service date, not to extend beyond twenty-four (24) month from date of manufacture, and
- Thirty-six (36) month warranty on all Stellar Crane and Hooklift structural parts from the date recorded by Stellar as the in-service date, not to extend beyond forty-eight (48) months from date of manufacture.

The in-service date will be derived from the completed warranty registration card. In the event a warranty registration card is not received by Stellar, the factory ship date will be used.

Stellar's obligation under this warranty is limited to, and the sole remedy for any such defect shall be, the repair and/or replacement (at Stellar's option) of the unaltered part and/or component in question. Stellar after-sales service personnel must be notified by telephone, fax, or letter of any warranty-applicable damage within fourteen (14) days of its occurrence. If at all possible, Stellar will ship the replacement part within 24-hours of notification by the most economical, yet expedient, means possible. Expedited freight delivery will be at the expense of the owner.

Warranty claims must be submitted and shall be processed in accordance with Stellar's established warranty claim procedure. Stellar after-sales service personnel must be contacted prior to any warranty claim. A return materials authorization (RMA) account number must be issued to the claiming party prior to the return of any warranty parts. Parts returned without prior authorization will not be recognized for warranty consideration. All damaged parts must be returned to Stellar freight prepaid; freight collect returns will be refused. Freight reimbursement of returned parts will be considered as part of the warranty claim.

Warranty service will be performed by any Stellar new equipment distributor, or by any Stellar-recognized service center authorized to service the type of product involved, or by the Stellar factory in the event of a direct sale. At the time of requesting warranty service, the owner must present evidence of date of delivery of the product. The owner shall be obligated to pay for any overtime labor requested of the servicing company by the owner, any field service call charges, and any towing and/or transportation charges associated with moving the equipment to the designated repair/service provider.

All obligations of Stellar and its authorized dealers and service providers shall be voided if someone other than an authorized Stellar dealer provides other than routine maintenance service without prior written approval from Stellar. In the case repair work is performed on a Stellar-manufactured product, original Stellar parts must be used to keep the warranty in force. The warranty may also be voided if the product is modified or altered in any way not approved, in writing, by Stellar.

The owner/operator is responsible for furnishing proof of the date of original purchase of the Stellar product in question. Warranty registration is the ultimate responsibility of the owner and may be accomplished by the completion and return of the Stellar product registration card provided with the product. If the owner is not sure of registration, he is encouraged to contact Stellar at the address below to confirm registration of the product in question. This warranty covers only defective material and workmanship. It does not cover depreciation or damage caused by normal wear and tear, accident, mishap, untrained operators, or improper or unintended use. The owner has the obligation of performing routine care and maintenance duties as stated in Stellar's written instructions, recommendations, and specifications. Any damage resulting from owner/operator failure to perform such duties shall void the coverage of this warranty. The owner will pay the cost of labor and supplies associated with routine maintenance.

The only remedies the owner has in connection with the breach or performance of any warranty on the Stellar product specified are those set above. In no event will Stellar, the Stellar distributor/dealer, or any company affiliated with Stellar be liable for business interruptions, costs of delay, or for any special, indirect, incidental, or consequential costs or damages. Such costs may include, but are not limited to, loss of time, loss of revenue, loss of use, wages, salaries, commissions, lodging, meals, towing, hydraulic fluid, or any other incidental cost.

All products purchased by Stellar from outside vendors shall be covered by the warranty offered by that respective manufacturer only. Stellar does not participate in, or obligate itself to, any such warranty.

Stellar reserves the right to make changes in design or improvement upon its products without imposing upon itself the same upon its products theretofore manufactured.

This warranty will apply to all Stellar Hooklifts, Stellar Service Trucks, & Truck-mounted Cranes shipped from Stellar's factory after July 1, 2005. The warranty is for the use of the original owner only and is not transferable without prior written permission from Stellar.

THIS WARRANTY IS EXPRESSLY IN LIEU OF ANY OTHER WARRANTIES, EXPRESS OR IMPLIED, INCLUDING ANY WARRANTY OF MERCHANTABILITY OR FITNESS FOR A PARTICULAR PURPOSE. REMEDIES UNDER THIS WARRANTY ARE LIMITED TO THE PROVISION OF MATERIAL AND SERVICES, AS SPECIFIED HEREIN. STELLAR INDUSTRIES, INC. IS NOT RESPONSIBLE FOR INCIDENTAL OR CONSEQUENTIAL DAMAGES.

Revision Date: February 2007

Document Number: 37040